

DAYALBAGH EDUCATIONAL INSTITUTE

(Deemed to be University)

DAYALBAGH, AGRA 282005



Tender for

- 1. Construction of Bamboo Hall No. - I
(North of Faculty of Arts)**
 - 2. Construction of Bamboo Hall No. - II
(East of Computer Centre)**
- for DEI**

INDEX

Section – I

NOTICE INVITING TENDER	06
------------------------------	----

Section – II

TENDER FORM

Tender submission by the contractor.....	09
Submission of details by the contractor	11
Details of similar works done	13
Details of on going works	14

Section – III

SPECIAL CONDITIONS OF CONTRACT

Site of Work	15
Scope of Work	15
Tender	15
Sub Contract	15
Supervision of work / man power	15
Taxes	15
Insurance.....	15
Specifications	15
Materials	16
Drawings and construction schedule	16
Security	16
Construction Power supply	16
Defectiability	16
Labour	16
Coordination	17
Misc. (Sr.No. 16 to 26)	17
Sr.No. 27	18

Section - IV

GENERAL CONDITIONS OF CONTRACT

1 GENERAL PROVISIONS

1.1	Definitions	20
1.2	Interpretation	22
1.3	Law and Language	23
1.4	Priority of Documents	23
1.5	Contractor's Documents for use by DEI	23
1.6	DEI's Documents for use by Contractor	24
1.7	Compliance with law	24
1.8	Changes in Constitution.....	24

2 THE DEI

2.1	Possession of Site	25
2.2	Permits, Licenses or Approvals	25
2.3	DEI's Personnel	25
2.4	DEI Claims	25

3 THE ENGINEER IN CHARGE

3.1	Engineer-in-charge's Duties and Authority.....	26
-----	--	----

3.2	Instructions of the Engineer-in-charge	26
3.3	Replacement of the Engineer-in-charge.....	27

4 THE CONTRACTOR

4.1	Contract Documents	27
4.2	Security Deposit	28
4.3	Refund of Security Deposit	29
4.4	Sub-contracts	29
4.5	Construction Coordination	29
4.6	Setting out the work	29
4.7	Quality Compliance.....	30
4.8	Sufficiency of Accepted contract amount	30
4.9	Reporting of Hindrances	30
4.10	Supply of Goods	30
4.11	Transport of Goods	30
4.12	Contractor's Equipment	30
4.13	Protection of the Environment	31
4.14	Electricity	31
4.15	Work during Night or on Sunday and Holidays	31
4.16	Material obtained from Excavation	31
4.17	Treasure, Trove, Fossils, etc.	31
4.18	Site Drainage	32
4.19	Protection of Trees	32
4.20	Security of the site	32
4.21	Co-operation and Facilities to other Contractors	32
4.22	Water Supply	32
4.23	Land	32

5 STAFF, LABOUR AND INDUSTRIAL SAFETY

5.1	Engagement of Staff and Labour	33
5.2	Rates of Wages and Conditions of Labour	33
5.3	Persons in the Service of DEI and other contractors	34
5.4	Labour Laws	34
5.5	Facilities for Staff and Labour	35
5.6	Health and Industrial Safety	35
5.7	Contractor's supervision for compliance	36
5.8	Contractor's Personnel	36
5.9	Records of Contractor's Personnel	36
5.10	Disorderly conduct	37
5.11	Other compliance	37
5.12	House Keeping	37

6 PLANT, MATERIALS AND QUALITY ASSURANCE

6.1	Tools, Plants & Equipments	37
6.2	Workmanship	37
6.3	Materials & Samples	38
6.4	Inspection	38
6.5	Testing	39
6.6	Rejection	39
6.7	Remedial Work	39

6.8	Ownership of plant and Materials	40
6.9	Octroi, Cess, Taxes, Royalties, etc	40
6.10	Urgent works	40
6.11	Material Issued by the DEI	40
6.12	Material Accounting	41
7	COMMENCEMENT, DELAYS AND SUSPENSION	
7.1	Commencement of work and completion time	41
7.2	Program	41
7.3	Early Detection of Hinrances	42
7.4	Hindrances	42
7.5	Rate of Progress.....	43
7.6	Extension of Time for Completion	43
7.7	Compensation of delay	43
7.8	Suspension of work for period upto 90 days	44
7.9	Prolonged Suspension of work (beyong 90 days).....	44
7.10	Payment for plant and materials in event of suspension.....	45
7.11	Resumption of work	45
8	DEI'S TAKING OVER	
8.1	Completion certificate	46
9	DEFECTS LIABILITY	
9.1	Rectification of Defects	46
10	MEASUREMENT AND EVALUATION	
10.1	Records & Measurement	47
10.2	Method of Measurement	48
11	VARIATION AND ADJUSTMENT	
11.1	Right to very	48
11.2	Payment for Variation	48
11.3	Contract Price Adjustment	48
12	CONTRACT PRICE AND PAYMENT	
12.1	Mobilisation Advance	51
12.2	Payment of Running Bills	51
12.3	Over Payment and Unde Payment	52
12.4	Time limit for Payment of Final Bill	52
13	CONTRACT TERMINATION BY DEI	
13.1	Foreclosure of contact	53
13.2	Determination / Cancellation of contact	53
13.3	Termination of Contact on death	56
14	RISK AND RESPONSIBILITY	
14.1	Liability for damage, defects or imperfections and rectification there of.....	56

15	FORCE MEJEURE	
15.1	Definition of Force Majeure	57
15.2	Consequence of Force Majeure	57
15.3	Duty to Minimise Delay	57
16	CLAIMS DISPUTES AND ARBITRATION	
16.1	Contractor' s Claims	58
16.2	Dispute Resolution	59
16.3	Appoinment of the Dispute Resolution Board	59
16.4	Obtaining Dispute Resolution Board's Decision	60
16.5	Amicable Settlement	60
16.6	Failure to Comply with Dispute Resolution Board's Decision	61
16.7	Expiry of Dispute Resolution Board's Appoinment	61
16.8	Arbitration	61
17	SCHEDULE	
	SCHEDULE 'A'	63
	SCHEDULE 'B'	64
	FORMAT FOR HINDRANCE REGI'STER'	65
18	CONTRACTOR'S LABOUR REGULATIONS AND FORMS	
	Annexure – A [Obligations of Contract(s)].....	69
	Proposed Guidelines for safety precautions.....	70
	Appendix – I Register of worksmen (Regulation 7)	71
	Appendix - II Employment Card (Regulation 8).....	72
	Appendix – 3 Register of Wages cum Muster Roll (Regulation 9)	74
	Appendix – 4 Wage Slip (Regulation 9).....	76
	Appendix – 6 Register of Fines (Regulation 10(vii)).....	77
	Appendix – 7 Register of Deductions for damage or Loss caused to DEI ... (Regulation 10(vii)	78
19	DISPUTES RESOLUTION BOARD AGREEMENT	79
Section – V	SPECIFICATIONS	82
Section – VI	TENDER DRAWINGS	83- 88
Section – VII	SCHEDULE OF MATERIALS TO BE SUPPLIED BY DEI	89
Section – VII	SCHEDULE OF QUANTITIES OF WORK	90 – 102

Notice Inviting Tender

Section - I

Tender No DEI/Works/KVL/2019-20/DR-07

Dated 27/05/2019

1. Sealed Tender are invited on behalf of the DEI by the Registrar from Contractors who have executed similar works for construction of (i) Bamboo Hall No. – I (North of Faculty of Arts), and (ii) Bamboo Hall No. –II (East of Computer Centre) for DEI. The work is estimated to cost Rs. **160.42 lakhs** including cost of construction material which shall be supplied by DEI on payment and excluding cost of construction material which shall be provided by DEI free of cost. This estimate however, is given merely as a rough guide.
2. Completion time **six** (in months) (including monsoon period)
3. Director, DEI shall be the “Accepting Authority” hereinafter referred to as such for the purpose of this contract.
4. Tender document may be downloaded and the hard copy submitted at the time of tender opening.
5. The bid is to be submitted in TWO Bid Pattern i.e. Techno- Commercial Bid and Price Bid in Two separate sealed covers / envelopes. Both envelopes to be put in one big envelope.
6. The tender fee of Rs. 200.00 (non-refundable) may be submitted along with the Techno-Commercial Bid in the form of Demand Draft in favour of “Registrar, Dayalbagh Educational Institute, Agra” payable at Agra.
7. Tenderers shall submit list of works which are in hand at the time of submitting their tender, giving name of work, name and particulars of location where the work is executed, cost of work and position of work in progress.
8. Balance sheet of last three years should be submitted along with the Techno Commercial Bid. Alternatively a certificate from a CA certifying the turnover etc. may be submitted.
9. Solvency certificate for **Rs.50.00 lakhs** issued by a nationalized or a scheduled bank to be submitted along with the Techno Commercial bid.
10. Copies of other documents and drawings pertaining to the work are part of the bid document. However bidders are free to contact the Superintendent of Works, DEI for any clarification.
11. The tenderers are advised to inspect and survey the site and its surroundings and satisfy themselves before submitting their tenders.
12. Submission of a tender by a tenderer implies that he has read this notice and all other contract documents and has made himself aware of the scope and specification of the work to be done and of conditions and rates at which stores, tools and plant, etc, will be issued to him by the D.E.I. and local conditions and other factors bearing on the execution of works.
13. The tenderer should quote his rates in figures as well as in words. The amount for each item should be worked out and the requisite totals given. The total amount shall be written both in figures and in words.
14. A pre-bid conference shall be held in the office of the Registrar, DEI on **16.06.2019** at 12.00 hours to clear all doubts of the intending bidders, if any.

15. Tenders shall be received by office of Registrar upto 11.00 hours on 25.06.2019 (date) and shall be opened at 12.00 hours on the same day in the presence of those tenderers who may be present.
16. The tender shall be accompanied by earnest money of Rs.3.20 lacs along with the Techno Commercial Bid. The earnest money may be paid in any one of the following forms :-
 - (a) Demand Draft of any Scheduled Bank drawn in favour of the D.E.I. payable at Agra.
 - (b) Fixed Deposit Receipt issued by Scheduled Banks endorsed/pledged in favour of the D.E.I.

Tenders not accompanied by EMD shall be rejected.
17. On acceptance of tender, earnest money will be treated as part of security deposit.
18. The tenderer shall submit the tender which satisfies each and every condition laid down in the tender documents, failing which, the tender is liable to be rejected.
19. The D.E.I. do not bind themselves to accept the lowest or any tender or to give any reasons for their decision.
20. The D.E.I. reserve to themselves right of accepting the whole or any part of the tender and the tenderer shall be bound to perform the same at his quoted rates.
21. Notice Inviting Tender shall form part of the contract document.
22. Applicable GST and any other taxes and duties in respect of this contract shall be payable by the contractor and reimbursed by DEI on production of valid receipt.
23. The tenders submitted shall remain valid for acceptance for a period of 90 days from the date set for opening of the tender. The tenderer shall not be entitled during the said period of validity to revoke or cancel his tender or vary the tender given or any item thereof.

In case of tenderer revoking or cancelling his tender, varying any terms in regard thereof, the earnest money paid by the tenderer along with the tender shall be forfeited by D.E.I.

The demand drafts (validity 45 days beyond final bid) for earnest money deposit and tender fee must be enclosed in the envelope containing the Techno-Commercial bid addressed to :-

“The Registrar”
Dayalbagh Educational Institute
Dayalbagh, Agra – 282005,
Uttar Pradesh

- | | |
|---|--|
| 1. Time and date for pre bid conference | : 12.00 hours on 16.06.2019 |
| 2. Time and last date for submission of Techno – Commercial bid and Price Bid | : 11:00 hours on 25.06.2019 |
| 3. Time and date of opening of Techno – Commercial Bid | : 11:30 hours on 25.06.2019 |
| 4. Venue of opening of Techno – Commercial Bid | : CAO, Dayalbagh Educational Institute
In the presence of bidders who wish to be present at the time of opening of bid. |

5. Date of opening of price bid

: 30.06.2019

Interested Contractors may put the tender document complete in all respect and other requisite documents in the tender box kept in the General Section, CAO, Dayalbagh Educational Institute, Dayalbagh, Agra-282005. The bidders are informed that they may come personally or send their representative to be present at the time of opening of bid. Please note that the tender box shall be opened at the time mentioned above irrespective of whether bidders themselves or any of their representatives are present or not. The tenders shall not be entertained after this deadline under any circumstances what so ever. For more information please visit institute website <http://www.dei.ac.in> or contact Sh. K V Layal – 9997136118.

For and on behalf of the D.E.I.

Designation : REGISTRAR

Date :

Email : registrar.dei@gmail.com

TENDER FORM

Section – II

TENDER

To,
Dayalbagh Educational Institute
Dayalbagh, Agra

I/We have read and examined the following documents relating to TENDER No. **DEI/Works/KVL/2019-20/DR-07 Dated 27.05.2019** for the work “Construction of Bamboo Hall No. – I and Bamboo Hall No. - II for DEI”

- a) Notice Inviting tender
- b) Tender form
- c) Special Conditions of contracts
- d) General Conditions of contract including Contractors labour Regulations Model Rules for Labour Welfare and Safety Code appended to these conditions together with the amendments, (if any) and Schedule ‘A’, ‘B’ & ‘C’.
- e) Technical Specifications
- f) Schedule of quantities

I/We hereby tender for execution of the work referred to in the aforesaid documents upon the terms and conditions contained or referred to therein and in accordance in all respects with the specifications, designs drawings and other relevant details at the rates contained in Schedule of Quantities.

In consideration of I/We being invited to tender, I/We agree to keep the tender open for acceptance for 90 days from the due date of submission there of and not to make any modifications in its terms and conditions which are not acceptable to DEI.

A sum of Rs. 3.20 lacs is hereby submitted as EMD. If I/We fail to keep the tender open as aforesaid or make any modifications in the terms and conditions of the tender which are not acceptable to the D.E.I. I/We agree that the D.E.I. shall without prejudice to any other right or remedy, be at liberty to forfeit the said earnest money absolutely. Should this tender be accepted. I/We hereby

agree to abide by and fulfill all the terms, conditions and provisions of the aforesaid documents.

If, after the tender is accepted, I/We fail to commence the execution of the works as provided in conditions, I/We agree that the D.E.I. shall without prejudice to any other right or remedy be at liberty to forfeit the said earnest money absolutely.

Signature of the Capacity of

Duly authorized to sign the tender on behalf of the

(in block Capital) _____

Date _____

Postal Address _____

e-mail I.D. _____

Telephone No. /Fax No. _____

Seal of the Company/Firm _____

Witness _____

Address _____

To,
The Registrar
Dayalbagh Educational Institute
Dayalbagh, Agra

Sub : Submission Tender No. DEI/Works/KVL/2019-20/DR-07 Dated 27.05.2019
Name of work : "Construction of Bamboo Hall No. – I and Bamboo Hall No. – II"
for DEI"

Dear Sir,

With reference to the tender of above work, I/We furnish the following details duly filled in by us.

1. Name of Contractor : _____
2. Address (For Correspondence) : _____

e-mail

Phone No

3. Name of Applicant :

4. Nationality :

5. State of the contractor

- a) Whether sole proprietor Yes/No
b) Whether a partnership firm Yes/No (with a copy of deed)
c) Whether a private Ltd. Co. Yes/No (with a certificate of incorporation issued by the Registrar of Companies)
d) Whether a public Ltd. Co. Yes/ No

6. Place of Business :

7. Address for correspondence :

8. a) Whether applicant has power of attorney holder Yes/No
b) If yes, Xerox copy enclosed Yes/No

9. Class/Details of Registration (quote registration No. & its class indication amount upto which tender can be accepted)

Department

Class

Amount Limit

- a) Registered with CPWD as
b) Registered with State PWD as
c) Registered with Rlys. Deptt. as
d) Registered with MES Deptt. as

- e) Registered with PSU _____ as _____
f) I am / we are, not registered / approved contractor in any Deptt.

10. Permanent A/c No. Allotted by I.T. Deptt. _____
(with copies of Income Tax returns for last three years enclosed)

11. GST Registration No. _____ Copy enclosed Yes/NO.

12. Name of bank with which transactions are made with IFSC, Branch code etc. :

13. List of machineries, equipments, vehicles and other tool & plant available with our firm is enclosed.

14. EMD in the form of DD / FD / BG of Rs. _____

Dated _____

15. Solvency certificate submitted amounting to Rs. _____ dated _____ issued by
_____ (name of bank)

16. Total no(s) of enclosures : In figure _____
in words _____

It is further certified that to the best of my/our knowledge the details furnished above are correct.

Date :

(Signature of Contractor)

Seal

DAYALBAGH EDUCATIONAL INSTITUTE

DAYALBAGH, AGRA

Name of work: "Construction of Bamboo Hall No. – I and Bamboo Hall No. - II for DEI"

Name of Tenderer

Form-I: DETAILS OF SIMILAR WORKS DONE DURING THE PAST SEVEN YEARS.

(To be included in the Tender)

Sl No	Full Postal Address of Client & Name of Officer- in-charge	Description of the work	value of Contract	Name & Address of Sub-contracting agencies employed if any	Completion time started Tender (month)	Date of commencement of work	Actual completion time (month)	Year of Completion	Remark, if any
1	2	3	4	5	6	7	8	9	10

NOTE: A copy of completion certificate and work order copy of each work mentioned above shall be submitted by the tenderer along with the tender document. For works done under private bodies, TDS Certificates in support of payment received against work done shall be submitted compulsorily for verification purpose.

(Signature of Tenderer)

DAYALBAGH EDUCATIONAL INSTITUTE

DAYALBAGH, AGRA

Name of work: "Construction of Bamboo Hall No. – I and Bamboo Hall No. - II for DEI"

Name of Tenderer

Form-II: DETAILS OF ON GOING WORKS.

(To be included in the Tender)

Sl No	Full Postal Address of Client & Name of Officer- in-charge	Description of the work	value of Contract	Name & Address of Sub-contracting agencies employed if any	Completion time started Tender (month)	Date of commencement of work	Actual completion time (month)	Year of Completion	Remark, if any
1	2	3	4	5	6	7	8	9	10

(Signature of Tenderer)

Section – III

SPECIAL CONDITIONS OF CONTRACT

1. The proposed site of work is at DEI campus, Dayalbagh , Agra.
2. **SCOPE OF WORK**
“Construction of Bamboo Hall No. – I and Bamboo Hall No. - II for DEI”
3. **TENDER**

The contractor shall submit all details to be filled in the enclosed application format, which is for the purpose of evaluation of technical bids along with their offer(s).

 - (3.1) If the tender is being submitted by a firm, it must be signed separately by each partner thereof or in the event of the absence of any partner, it must be signed on his behalf by person holding a power of attorney authorizing him to do so, such power of attorney to be produced with the tender, and it must disclose that the firm is duly registered under the Indian Partnership Act 1932.
 - (3.2) In the case of any tender where unit rate of any item/items appear unrealistic such tender will be considered as unbalanced and in case the tenderer is unable to provide satisfactory explanation such a tender is liable to be disqualified and rejected.
4. **SUB CONTRACTS**

The contractor shall not sub-contract the work for any portion of the work with out the prior written approval of the Engineer-in-Charge.
5. **SUPERVISION OF WORK/MANPOWER**

The contractor shall employ adequate supervisory staff and manpower.
6. **TAXES**
 - (6.1) “Price quoted is inclusive of all applicable statutory payments such as EPF, WCT, etc. Any increase in the rate of the applicable statutory payments, or any new taxes, duties or levies imposed after opening of bids is payable as extra. GST will be paid extra on production of valid receipts.”
 - (6.2) All other taxes : Income Tax, and surcharge or any other statutory levy on works contract as notified by central / State Government from time to time shall be recovered from your running account bills as well as final bills for this work, in the prescribed manner.
7. **INSURANCE**

The contractor shall arrange group Insurance in respect of all workmen engaged in this work for entire period and documents in this regard should be submitted to Engineer-in-Charge with 7 days after issue of letter of Intent/work order.
8. **SPECIFICATIONS**

Work shall be carried out as per CPWD specifications (amended up to latest correction slips).

9. MATERIALS

- (9.1) Contractor should note that all the construction materials excluding cement, reinforcement steel TMT , electrical wires and fittings, ‘water supply and sanitary pipes and fittings’ are to be arranged by the contractor himself as per given schedule Section VII.
Any material not included in the schedule but required for the work shall be arranged by the contractor and got approved by the EIC before use. In case the material is available with the DEI, same may be issued at the issue rate plus 10% overheads
- (9.2) Whenever dimension for the material, to be used in work are given in foot, pound units, materials with nearest metric dimension may be used with prior approval of the Engineer. No variation in the rates will be made on account of this minor change
- (9.3) Contractor shall maintain records of costly materials like steel, cement, pipes etc. at site of work. It is required to submit receipt and consumption records of the material for periodical checks by Engineer in charge
- (9.4) It should be noted that separation of alternative item if any, in the schedule of quantities will be entirely at the discretion of the Engineer.
- (9.5) The contractor has to construct sheds for storage of cement & other costly materials at their own expense for a capacity as instructed by the Engineer in Charge.

10. DRAWING AND CONSTRUCTION SCHEDULE

Supply of construction drawings will be phased to suit the construction schedule. However, the contractor shall submit his actual working construction schedule within 10(Ten) days after issue of Letter of Intent/work order.

11. SECURITY

The contractor shall follow at site security rules regarding removal of material from site, issue of identity cards etc. as may be framed from time to time by the D.E.I.

12. CONSTRUCTION POWER SUPPLY

Electricity shall be supplied free of cost by DEI. No recovery on account of power consumption will be done under this contract.

13. DEFECTLIABILITY

During the execution of the contract and until completion certificate is used, the contractor is fully liable to compensate in all respect for any loss, damages or destruction of work, structure, property etc. including third party risk arising due to causes attributable to him which will be decided by the Engineer-in-Charge whose decision in this regard will be final.

14. LABOUR

The contractor shall comply with various provision of the contract labour, Partly mentioned vide Annexure ‘A’ in the tender (Regulation and Abolition Act-1970) and rules framed there under from time to time. In case the contract labour Act does not apply to the organization concerned contractor should intimate the Engineer-in-Charge. Before commencing the work further they shall also comply with the provisions of other laws such as Workmen’s Compensation Act 1923, Minimum Wages act 1948, E.P.F. Act., Gratuity Act and other labour laws as applicable to the organization. In case DEI is required to incur any expense as principal employer under provision of the various laws, recovery of the same shall be made from the contractor.

15. CO- ORDINATION

The tenderer shall note that they shall have to carry out this work in close coordination with other contractors / agencies working in the same premises.

16. Conditional tenders are liable to be rejected.

17. The rate of each item shall be quoted independent of other items. Any items can be deleted entirely which shall not entitle the Contractor to any claim or relief.

18. The tenderers are requested to write their tendered rate legible in English both in figure and words. In case of any difference in any rates between the figures and words, the one written in words will be taken as correct.

19. The contractor shall arrange for his own T & P necessary for the execution of the work and the Registrar does not undertake to supply them any T & P. The EIC at his discretion may, however, lend to the Contractor available T & P. That can be spared for which rent at the prescribed rate will be charged from the Contractor.

20. Rates quoted by the contractor shall be rates for finished work and shall include all applicable taxes, like District tax or District Board Tax or Municipal Board Tax and income tax etc. No request for subsequent reimbursement of any tax, whatsoever, will be entertained.

21. The cost of labour for setting out work making bench marks outlining or reference pillar etc. as approved by the EIC shall be entirely borne by the Contractor as included in the overall tendered rates or if any such labour has to be employed by the EIC the contractor will bear its full cost.

22. Every attempt will be made to give materials, listed in the schedule attached to the contractor in time according to his progress but for delays any compensation except for extension of time limit by an equivalent number of days will not be entertained.

23. On the completion of his work the contractor shall leave the site of work neat and clean. He shall remove from the site covered by the works and its vicinity all surplus stores or waste materials rubbish etc. at his own cost to the satisfaction of the EIC. In case, he fails to do so this work shall be got done by the EIC and recovered from the contractor.

24. All work shall be carried out in accordance with the drawings issued from time to time. Contractors are advised to see the site of building fully and in detail.

25. No claim for work done during night time shall be entertained and no extra payment, whatsoever, shall be made on this account.

26. The contractor shall at all times exercise reasonable precaution for the safety of employees on the work and shall comply with the provision as may be applicable of safety laws and building constructions code as issued from time to time. All equipment and other physical hazards shall be guarded against in accordance with the regulations of laws of the Government of U.P. Monthly reports of all accidents shall be promptly submitted to the EIC giving such date as may be prescribed.

27. Water / Power connection of the construction work shall be arranged by EIC at one point near construction site. Water tank at the site for storing water, mortar mixing platform, lime tank etc. shall be constructed by the contractor at his own cost. However water shall be provided free of cost.
28. In case of any discrepancies / omissions in the contract clauses, the decision of the engineer in charge shall be final based on the CPWD norms.
29. All bamboos used for construction should be well treated for preservation and for protection from insects, rot and decay. The following varieties of bamboos should be used :-
- a) For 1.5” to 2.2” dia bamboos with top end dia 1’ to 1.5”
 - Thyrsostachys oliverii
 - b) For 3.5” to 4.5” dia bamboos with minimum wall thickness 10 mm
 - Bamboosa balcooa

REGISTRAR

Dayalbagh Educational Institute

Dayalbagh, Agra

All above special conditions are acceptable

Signature of the
Contractor

Section - IV

DAYALBAGH EDUCATIONAL INSTITUTE

(Deemed University)

DAYALBAGH

**GENERAL CONDITIONS OF CONTRACT
FOR WORK**

1. GENERAL PROVISIONS

1.1 Definitions

- 1.1.1 “**Accepting Authority**” shall mean the Director, DEI
- 1.1.2 “**Contract**” shall mean an agreement where a proposal has been accepted and shall include notice inviting the tender, the tender and acceptance thereof and the formal agreement, if any, executed between DEI and the Contractor together with the documents referred to therein including these conditions with appendices and any special conditions, specification, designs, drawings, schedule of quantities with rates and amounts. All these documents taken together shall be deemed to form one contract and shall be complementary to the another.
- 1.1.3 “**Contractor**” is a person(s) named as contractor in the work order/agreement and its legal successors.
- 1.1.4 “**Contract Price**” shall mean :
- (i) In the case of “**Lumpsum Contracts**”, the sum for which the tender is accepted.
 - (ii) In the case of “**Item Rate Contracts**”, the cost of the works arrived at after extension of quantities shown in Schedule of Quantities by the item rates quoted by the tenderer of various item.
- 1.1.5 “**Commissioning**” means the trial/initial operation of the works/facility of any part thereof by the contractor, for the purpose to demonstrate successful operation of the facility as per contract provisions.
- 1.1.6 “**Completion Certificate**” means the certificate issued by the DEI on completion of work in accordance with sub clause 8.1 (Completion Certificate)
- 1.1.7 “**Completion Time**” means the time within which completion of the works or part (where a separate time of completion of such part has been prescribed) is to be completed as stipulated in the work order and in accordance with the provisions of contract.
- 1.1.8 “**Contract Documents**” means documents listed in the contract agreement including any amendments therein to.
- 1.1.9 “**Contractors’ Equipment**” means all apparatus, machineries, vehicles and other things required for the execution and completion of the work and remedying of any defects. However, contractors equipment excludes temporary works, employers equipment (if any), plant, materials and any other things intended to form or forming part of the works.
- 1.1.10 “**Contractors’ Representative**” means the person nominated or appointed time to time by the contractor who acts on behalf of the contractor.
- 1.1.11 “**DEI’s Tools & Plants**” means the apparatus, machinery, tools, plant and vehicles (if any) made available by the DEI fir the use of the contractor in the execution of the work but it does not include plants which has not been taken over by the DEI.
- 1.1.12 “**Country**” means the country in which the site is located where the works are to be executed.

- 1.1.13 **“Date of Commencement”** means the date when the contractor shall commencement execution of the works as mentioned in the work order and the completion time for the work shall be reckoned from this date.
- 1.1.14 **“A Day”** means a day of 24 hours from mid-night to mid-night irrespective of the number of hours worked in that day, a **“Week”** means seven days, a **“Month”** means a calendar month and a **“Year”** means 365 days without regard to the number of hours worked in any day.
- 1.1.15 The **“Defect Liability Period”** is the period defined in the Schedule “A” during the contractor is responsible for defects with respect to the works as provided in GCC clause No. 9 (Defect Liability)
- 1.1.16 **“Defect”** means any part of the works not executed in accordance with the contract specifications.
- 1.1.17 **“Drawings”** means the drawing of the works, an included in the contract, and any additional and modification drawings issued by (or on behalf of) the DEI in accordance with the contract.
- 1.1.18 **“DRB”** means the Dispute Resolution Board appointed under sub-clause 17.3 (Appointment of the Dispute Resolution Board).
- 1.1.19 **“Engineer-in-Charge”** shall mean the officer appointed by the DEI or his duly authorized representative who shall direct, supervise and be incharge of the works for purposes of this contract.
- 1.1.20 **“Excepted Risks”**, are the risks due to riots (other than that among Contractor’s employees) and civil commotion (in so far as both these are uninsurable), war (whether declared or not), invasion, act of foreign enemies, global terrorism, civil war, rebellion, munitions of war, explosive materials, ionizing radiation or contamination by radio activity, revolution, insurrection, military or usurped power, any act of government, damage from aircrafts, sabotage, acts of God such as earthquake, lightning, cyclone, Tsunami and unprecedented floods and other causes over which the contractor has no control and accepted as such by the Accepting Authority or causes solely due to use or occupation by the “DEI” of the part of works in respect of which a certificate of completion has been issued.
- 1.1.21 **“GCC”** means the General conditions of contract.
- 1.1.22 **“Latent Defects”** shall mean any defects which exist but has not surfaced at the time of testing and has not manifested during defect liability period.
- 1.1.23 **“Laws”** means all national (or state) legislation, statutes, ordinances and other laws and regulations and by-laws of any legally constituted public authority.
- 1.1.24 **“Local Currency”** means the currency of India. **“Foreign Currency”** means the currency in which part (or all) of the Contract is paid in currency other than the local Currency.
- 1.1.25 **“Market Rate”** shall be the rate as decided by the Engineer-in-Charge on the basis of the cost of materials and labour at the site where the work is to be executed, plus 15% to covered all overhead and profit.
- 1.1.26 **“Minimum Wages”** shall be the minimum wages declared from time to time by the state government.

- 1.1.27 **“Near Relatives”** means wife, husband, parents and grant parents, children and Grand children, brothers and sisters, uncles and aunts, cousins and their corresponding in-laws.
- 1.1.28 **“Part Completion Certificate”** means the certificate issued by the DEI on completion of items or group of items for which separate period of completion have been specified in the contract, issued in accordance with Sub clause 8.1 (Completion Certificate).
- 1.1.29 **“Party”** shall mean DEI or contractor, as the context requires.
- 1.1.30 **“Retention Money”** means the accumulated retention money which the DEI retains from the Running Bills.
- 1.1.31 **“Schedule(s)”** referred to in these conditions shall mean the relevant schedule (s) annexed to the tender papers issued by the DEI.
- 1.1.32 **“Schedule Commercial Bank”** In India as per definition of Reserve Bank of India shall include of the following bank groups (i) Sate Bank of India and its associated, (ii) Nationalized Bank, (iii) Regional Rural Banks, (iv) Foreign Banks and (v) Other Indian Schedule Commercial Bank (in the private sector).
- 1.1.33 **“Site”** means the places where works are to be executed, including storage and working areas, and to which plant and materials are to be delivered and any other places as may be specified in the Contract as forming part of the Site.
- 1.1.34 **“Specification”** means the CPWD specifications and any modification/addition made or approved by the Engineer-in-charge.
- 1.1.35 **“Sub Contractor”** means any person named in the Contract as a Sub-Contractor, or any person appointed as a Sub-Contractor, for a part of the works; and the legal successor in the title to each of these persons. Piece rate Contractors are not to be considered as Sub-Contractor.
- 1.1.36 **“Temporary Works”** shall mean all temporary works of every kind required in or about the execution, completion or maintenance of the works.
- 1.1.37 **“Urgent Works”** shall mean any urgent measures which, in the opinion of Engineer-in-charge, become necessary during the progress of work to obviate risk of accident or failure or which become necessary for security and safety.
- 1.1.38 **“Variation”** is an instruction/communication given by Engineer-in-charge or his representative, which varies the works.
- 1.1.39 **“Work order”** is the formal communication by the DEI to the bidder whose bid has been accepted.
- 1.1.40 **“Works”** shall mean the works to be executed in accordance with the Contract or part(s) thereof as the case may be and shall include all extra or additional, altered or substituted works as required for execution of the contract. It shall include variation and urgent works. Any term which is not define herein but defined under difference enactment shall be construed to have the same meaning as defined in the act.

1.2 Interpretation

In the contract, except where the context requires otherwise :

- (a) Words indicating one gender include all genders;
- (b) Words indicating the singular also included the plural and vice versa;
- (c) The word 'tender' is synonymous with 'bid', 'tenderer' with bidder' and 'tender documents' with 'bidding documents', and
- (d) 'written' or 'in writing' means hand-written type-written, printed or electronically made, which would be produced physically as an evidence for the communication.

The marginal words and other headings shall not be taken into consideration in the interpretation of these conditions.

1.3 Law and Language

1.3.1 The contract shall be governed by the law of the country or other jurisdiction stated in the contract. The country unless otherwise stated in the contract shall be India.

1.3.2 The ruling language of the contract shall be English unless otherwise stated in the contract.

1.4 Priority of Documents

1.4.1 In the case of discrepancy between Schedule of Quantities, the special conditions, the Specifications and/or the Drawings, the following order of preference shall be observed.

- (a) Description in Schedule of Quantities and rates.
- (b) Special Conditions of contract, if any
- (c) Drawings
- (d) Technical specification
- (e) General Conditions of Contracts

1.4.2 Any inadvertent error in description, quantity or rate in Schedule of Quantities or any omission there from shall not vitiate the Contract or release the contractor from the execution of the whole or any part of the works comprised therein according to terms and conditions or from any of his obligation under the contract.

1.4.3 If there are varying or conflicting provisions made in any one document forming part of the contract, the Accepting Authority shall be the deciding authority with regard to the intention of the document.

1.5 Contractor's Documents for use by DEI

1.5.1 The contract shall maintain at his site office all drawings, specification and other contract documents and any other supplementary data complete with all the latest revisions thereto. The contractor shall also maintain, in addition, the continuous record of all changes to the above Contract documents, drawings, specifications, supplementary data etc effected at the site. Whenever called by Engineer-in-charge, the Contractor shall incorporate all such changes on the drawing and other engineering data to indicate actual construction/fabrication and erection carried out under the Contract. Two copies of such revised/updated drawings and engineering data shall be submitted to the Engineer in-charge along with the soft copies on completion of his total assignment to the milestones as specified under the contract.

- 1.5.2 The contractor shall be deemed (by signing the contract) to give to the DEI a non terminable transferable non-exclusive royalty-free license to copy, use and communicate the Contractor's Documents, including making and using modification of them. This license shall:
- (a) Apply throughout the actual or intended working life (whichever is longer) of the relevant parts of the works.
 - (b) entitle any person in lawful possession of the relevant part of the works to copy, use communicate the Contractor's Documents for the purposes of completing, operating, maintaining, altering, adjusting, repairing and demolishing the works, and
 - (c) in the case of Contractor's Documents, which are recorded in computer programs and other software, permit the access to the data through any computer on the Site.
- 1.5.3 The Contractor's Documents and other design documents made by (or on behalf of) the contractor shall not, without Contractor's consent, be used, copied or communicated to a third party by (or on behalf of) the DEI for purpose other than those permitted under this sub-clauses.

1.6 DEI's Documents for use by Contractor

- 1.6.1 The DEI shall retain copyright and other intellectual property rights of their Specification, the Drawing and other Documents made by (or on behalf of) the DEI. The contractor may, at his cost, copy, use, and obtain communication of these documents for the purpose of the contract. They shall not, without the DEI's consent in writing, be copied, used for communicated to a third party by the Contractor.

1.7 Compliance with Law

- 1.7.1 The contractor shall, in executing the contract, comply with applicable laws.

Unless otherwise stated :

- (a) The DEI shall have obtained (or shall obtain) the planning, zoning, building permit or similar permission for the Permanent Works, and any other permission described in the Specification as having been (or to be) obtained by the DEI; and the DEI shall indemnify and hold the contractor harmless against the from the consequences of any failure to do so; and
- (b) The contractor shall give all notices, pay all taxes, duties and fees, and obtain all permits, licenses and approvals, as required by the Laws in relation to the execution and completion of the works and the remedying of any defects; and the contractor shall indemnify and hold the DEI harmless against the from the consequences of any failure to do so, unless the Contractor is impeded to accomplish these actions and shows evidence of its diligence.

1.8 Changes in Constitution

- 1.8.1 Where the Contractor is a partnership firm, Joint Venture, collaborate or consortium, prior approval in writing of the Accepting Authority (defined by the DEI) shall be obtained before any change is made in the constitution of the firm. Where the Contractor is an individual or a Hindu Undivided Family business concern such approval as aforesaid shall likewise be obtained before the Contractor enters into any partnership firm which would have the right to carry out the work hereby undertaken by the Contractor.
- 1.8.2 Where the contractor is a partnership firm, Joint Venture, collaborate or consortium partnership the contractor shall intimate the DEI of any change or modifications in the terms with their

partnerships, which could happen between the submission of bids and awarding of bid. The contractor shall obtain prior approval in case of any such change or modification happens during the currency of the contract.

- 1.8.3 If prior approval as aforesaid is not obtained, the Contract shall be deemed to have been assigned in contravention thereof and the same action may be taken as provided for in the said clause 13.2 (Determination/Cancellation of Contract)

2 THE DEI

2.1 Possession of Site

- 2.1.1 The contractor shall not permitted to enter on (other than for inspection purposes) or take possession of the site until instructed to do so by the Engineer-in Charge in writing. The portion of the Site to be occupied by the Contractor shall be defined and / or marked on the Site Plan, failing which these shall be indicated by the Engineer-in-charge at site and the contractor shall on no account be allowed to extend his operations beyond these areas.
- 2.1.2 It is deemed that the Contractor has inspected and has full knowledge of the site.
- 2.1.3 The Engineer-in-charge shall give the Contractor right of access to and possession of , part of all parts of the site (as deemed necessary)with in the time specified in the Schedule A.
- 2.1.4 If no such time is stated in the Contract, the DEI shall give the Contractor right of access to, and possession of, the Site with in such times as required enable the Contractor to proceed without disruption in accordance with the program submitted.
- 2.1.5 The DEI may withhold the action on giving the right of access to an possession of site to the Contractor till the Performance Guarantee and acceptance of work order has been received.

2.2 Permits, Licenses or Approvals

- 2.2.1 The DEI shall provide, at the request of the Contractor such reasonable assistance or direction, which shall be limited to the issue of necessary certificates as required under law so as to allow the contractor to obtain the following:
- (a) copies of the Laws of the Country which are relevant to the Contract but are not readily available, and
 - (b) any permits, licenses or approvals required by the Laws of the Country which the Contractor is required to obtain under sub-clause 1.8 (Compliance with Law), for the delivery of Goods, including clearance through customs, and or the Export Contractor's Equipment when it is removed from the Site.
- 2.2.2 However, no claim can be made the Contractor with respect to this clause.

2.3 DEI's Personnel

- 2.3.1 The DEI shall be responsible for ensuring that the DEI's Personnel and the other Contractors deputed by DEI at the Site:
- (a) Co-operate with the Contractor's efforts under sub-clause 4.21 [Corporation and Facilities to other contractors], and

- (b) Take or facilitate actions similar to those which the Contractor is required to take under Sub-Clause 5.6 (Health and Industrial Safety) and Sub-Clause 4.13 (Protection of the Environment).

2.4 DEI Claims

- 2.4.1 If the DEI considers itself to be entitled to any payment under any clause of these conditions or otherwise in connection with the contract, and / or to any extension of the defect liability period, the Engineer-in-charge shall give notice and particulars to the Contractor. However, notice is not required for payments due under Electricity, Water and Gas, DEI's Equipment, Free- Issue Material and municipal taxes on land utilized for colony or for other services rendered by the DEI.
- 2.4.2 The Notice shall be given as soon as soon as practicable after the DEI became aware of the event or circumstances given rise to the claim. A notice relating to any extension of the Defects Liability Period shall be given before the expiry of such period.
- 2.4.3 The particulars shall specify the Clause or other basis of the claim, and shall include substation of the amount and / or extension to which the DEI consider itself to be entitled in connection with the Contract. The DEI shall set off or deduct against amount due, or otherwise to claim against the Contractor.

3 THE ENGINEER-IN-CHARGE

3.1 Engineer-In-Charge's Duties and Authority

- 3.1.1 The DEI shall nominate the Engineer-in-charge, who shall carry out the duties assigned to him in the Contract. The Engineer-In-Charge staff shall include suitably qualified engineers and other professionals who are competent to carry out these duties.
- 3.1.2 The Engineer-In-Charge is entitled to watch and supervise the works and to test and examine any materials to be used or workmen employed in connection with the works.
- 3.1.3 Engineer-In-Charge shall also certify and release payments for the work done and make deductions as per the contract.
- 3.1.4 The Engineer-in-charge may exercise the authority attributable to the Engineer in-charge as specified in or necessarily to be implied from the Contract. The DEI shall promptly inform the Contractor of any change to the authority attributed to the Engineer-in-charge.
- 3.1.5 Except as otherwise stated in these Conditions :
 - (a) Whenever carrying out duties or exercising authority, specified in or implied by the Contract, the Engineer-in-charge shall be deemed to act for the behalf of the DEI;
 - (b) Any approval, check, certificate, consent, examination, inception, instruction, notice, proposal, request, text, supervision or similar act by the Engineer- in-charge (including absence of disapproval) shall not relieve the Contractor from any responsibility he has under the Contract, including responsibility for errors, omissions, discrepancies and non-compliances.
 - (c) Any act by the Engineer-in-charge in response to a Contractor' request except otherwise expressly specified shall be notified in writing to be contactor within 30 days of receipt.

3.2 Instructions of the Engineer-in-charge

- 3.2.1 Subjects as otherwise provided in the Contract, all notices to be given on behalf of the DEI and all other actions to be taken on its behalf shall be given or taken by the Engineer-in-charge or any officer for the time being entrusted with the functions, duties and powers of the Engineer-in-charge.
- 3.2.2 All instructions, notices and communications, etc. under the contract shall be given in writing and if sent by registered / speed post to the last known place of abode or business of the Contractor, shall be deemed to have been served.
- 3.2.3 The contractor or his agent shall be in attendance at the site(s) during all working hours and shall supervise the execution of the works with such additional assistance in each trade as the Engineer-in-charge may consider necessary. Orders given to the Contractor' agent shall be considered to have the same force as if they had been given to the Contractor himself.
- 3.2.4 The Contractor shall comply with the instructions given by the Engineer-in-charge or delegated representative, on any matter related to the contract. Whenever practicable, their instructions shall be given in writing. If the Engineer in-charge or a delegated representative.
 - (a) gives an oral instruction,
 - (b) receives a written confirmation of the instruction, from the contractor, within 2 working days after giving the instruction, and (c) does not reply by issuing a written rejection and / or instruction with 7 working days after receiving the confirmation then the confirmation shall constitute the written instruction of the Engineer-in-charge or delegated representative (as the case may be)

3.3 Replacement of the Engineer-In-Charge

- 3.3.1 If the DEI intends to replace the Engineer-in-charge the DEI shall intimate the contractor of the name and designation of the intended replacement Engineer-in-charge.

4 THE CONTRACTOR

4.1 Contract Documents

- 4.1.1 The Specification and Drawings shall be in the custody and care of the DEI. unless stated in the Contract, two copies of the Contract documents and three copies o drawings shall be supplied to the Contractor free of charge.
- 4.1.2 Each of the Contractor's Documents shall be in the custody and care of the Contractor. The Contractor shall keep, on the site, a copy of the Contract, publications named in the specification the Contractor's Documents (if any), the Drawings and Variation and other communications given under the Contract. The Engineer-in-charge shall have the right of access to all these documents at all reasonable times.
- 4.1.3 If a party becomes aware of the error or defect in a document which was prepared for used in executing the works, the party shall promptly given notice to the other party of such error or defect.

4.2 Security Deposit

4.2.1 Total Security Deposit (SD) shall be calculated as under

- (i) Contract value up to Rs. 100 Crores - 10% of Contract Value.
- (ii) Contract Value more than Rs. 100 Crores - 5% of Contract Value subject to a minimum of Rs. 10 crores.

Note: The contract value for the purpose of this clause shall be taken as the value of the contract awarded.

4.2.2 Security Deposit as calculated based on above parameters shall be split in the following of two parts and furnished accordingly;

- a) Performance Guarantee to be submitted on award of work (50% of Security Deposit), and
- b) Retention money to be recovered from Running Bills (50% of Security Deposit).

4.2.3 Performance Guarantee: The Contractor shall deliver the performance Guarantee to the DEI within 15 days after issue of work order. The performance guarantee shall be issued by an entity and from within the country approved by the Employer, and shall be in the form of Bank Guarantee or FDR or any other form of deposit stipulated by the DEI.

4.2.4 Failure of the successful bidder to comply with furnishing the performance guarantee within 15 days as stated above shall constitute sufficient grounds for cancellation of the award of work.

4.2.5 Retention Money: Retention Money shall be deducted at the rate of 6% of the value of work done from Running Bills till the 50 % of Security Deposit amount so calculated as above, is built up. Total of Performance Guarantee & Retention Money should not exceed the amount of security deposit calculated as above.

4.2.6 When the retention money reaches the limit of 5 lakhs, the Contractor, if he so desires, may convert the amount into a Bank Guarantees as aforesaid.

4.2.7 In case a Fixed Deposit Receipt of any bank is furnished by the Contractor to the DEI as part of the contractor shall forthwith or on demand furnish additional security to the DEI to make good the deficit.

The DEI may deduct any sum of money payable by the Contractor under the terms of this Contract or any other Contract or any other account whatsoever from his security deposit. In the event of his security deposit amount being reduced by reasons of such deduction as aforesaid, the Contractor shall within 10 days of receipt of notice of demand from the Engineer-in-Charge make good the deficit.

4.2.9 FDR / Bank Guarantee shall be accepted only from Scheduled commercial banks in India.

4.2.10 NO interest will be paid on Security Deposit (Performance Guarantee and Retention Money).

4.3 Refund of Security Deposit

- 4.3.1 The retention money will be refunded to the Contractor after one month from the date of issue of Completion Certificate on receipt of request from the contractor, if as per the Engineer-in-Charge the balance amount of security deposit (Performance Guarantee) is sufficient to cover the Liabilities.
- 4.3.2 After the expiry of the Defects Liability Period, the balance amount of security deposit i.e. the Performance Guarantee shall be refunded by the Engineer-in-Charge to the Contractor. However, if any work remains to be executed under clause 9 [Defects Liability], the Engineer-in-Charge shall withhold the estimated cost of such rectification work until it is executed.

4.4 Sub-Contracts

- 4.4.1 The contractor shall not sub-contract the work or any portion of the work without the prior written approval of the Engineer-in-charge. Piece rate work shall not be deemed as sub contract. Sub contracting does not alter the Contractor's obligations and responsibilities.
- 4.4.2 The contractor shall not employ sub-contractor against whom the Engineer-in-charge raises reasonable objection by notice to the Contractor with supporting particulars.
- 4.4.3 The Contractor shall pay to the Sub-contractor the amount shown on the sub-contractor's invoices approved by the Contractor. The DEI may pay, direct to the Sub – contractor and for which the contractor has failed to make the payment. The contractor shall then repay, to the DEI, the amount which the sub contractor was directly paid by the DEI with interest at prevailing rate. If the contractor fails to repay, the same shall be adjusted against any dues payable to the Contractor along with interest for the intervening period. In this regard the decision of the Engineer-in-charge shall be final.

4.5 Construction Coordination

- 4.5.1 The field activities of the contractors working at the site will be coordinated by the Engineer-in-charge and his decision shall be final in resolving any disputes or conflicts between the contractor and regarding other contractors scheduling and co-ordination of work.
- 4.5.2 Engineer-in-charge shall hold periodic meeting with the contractors working at Site, at the time and a place to be designated by him. The Contractor shall attend such meetings and shall strictly adhere to the decisions taken during the meeting in executing his works.

4.6 Setting out the work

- 4.6.1 The Engineer-in-charge shall supply dimensioned drawings, levels and provide all necessary information to enable the Contractor to set out the works. The contractor shall make reasonable efforts to verify its accuracy before its use and the DEI shall not be responsible for any error at the subsequent stage unless it is found that such error has crept in as a result of incorrect data furnished in writing by the Engineer-in-charge. The Contractor shall protect preserve all reference baseline and bench marks used in setting out the works till the end of Defects Liability Period unless the Engineer-in-charge directs their earlier removal.

4.7 Quality Compliance

4.7.1 The construction / fabrication and erection of works under the scope of this contract shall be executed in accordance with the specifications and drawings. The Contractor shall adopt suitable quality assurance program, commensurate with DEI QA program.

4.8 Sufficiency of the Accepted Contract Amount

4.8.1 The contractor shall be deemed to have satisfied himself before tendering as to the correctness and sufficiency of his tender for the works and of the rates and prices quoted in the Schedule of Quantities. The rates and prices quoted by the Contractor in the Schedule of Quantities shall, except as otherwise provided, cover all his obligations under the Contract and all matters and resources necessary for the proper execution and completion of the works and the remedying of any defects till the end of defect liability period.

4.9 Reporting of Hindrances

4.9.1 The Contractor shall record hindrances if any, in the Hindrance register as specified in the sub clause 7.4 (Hindrances). Hindrances recorded and accepted by the Engineer-in-charge in the register shall be the basis for granting extension of time. The hindrance register shall be in the custody of the Engineer-in-charge.

4.10 Supply of Goods

4.10.1 The Contractor shall place purchase order well in time for supply of goods as deemed necessary as per the contract. He shall arrange to give notice sufficient in advance for necessary quality assurance at the place of manufacturing. The contractor shall submit as an unpriced copy of purchase order to Engineer-in-charge in order to ensure that all the requirements of technical specifications have been met.

4.11 Transport of Goods

4.11.1 Unless otherwise stated:

- a) The contractor give the Engineer in-charge not less than 10 days notice of the date of which any plant or a major item of other Goods will be delivered to the site;
- b) The contractor shall be responsible for packing, loading, transporting, receiving, unloading, storing and protecting all goods and other things required for the works.

4.11.2 The contractor shall indemnify and hold the DEI harmless against and from all damages, losses and expenses (including legal fees and expenses) resulting from the transport of Goods, and pay all claims arising from their transport.

4.12 Contractor's Equipment

4.12.1 The contractor shall bring only the required equipment for the executing of work and shall be responsible for all his equipments. The equipments when brought to the site shall be in working condition and deemed to be exclusively intended for the execution of this works. The Contractor shall not remove from the Site any major items of his Equipment without the written consent of the Engineer-in-charge. List of equipments brought to site shall be submitted to the Engineer-in-charge.

4.13 Protection of the Environment

- 4.13.1 The Contractor shall take all reasonable steps to protect and Environment (both on and off the site) and to avoid damage and nuisance to any people and property resulting from pollution, noise and other consequences of his operations.
- 4.13.2 Contractor shall not at any time do, cause or permit any nuisance on site ro do anything which shall cause unnecessary disturbance to owners, tenants or occupants of other properties near the site and to the general public.
- 4.13.3 The contractor shall ensure that emissions, surface discharges and effluent from the Contractor's activities shall not exceed the values stated in the Specification if any, or prescribed by applicable Law of the Land.

4.14 Electricity

- 4.14.1 Electric power, will be provide free of cost by the DEI at on point. All distribution system should be arranged for by the Contractor himself at his own cost, complying with all relevant act/ regulations. 'A' for the purpose of planning, the bidder shall furnish along with his bid, the estimated requirement of electric power for execution of work in terms of maximum demand and daily energy in kWh.
- 4.14.2 Disruption of supply or non-availability of electricity shall not entitle the Contractor for any claim for compensation either in time or money. He shall make prior arrangements for such contingency to carry on with the work without interruption.

4.15 Work during Night or on Sundays and Holidays

- 4.15.1 Prior written permission of the Engineer in-charge shall be taken whenever any works are proposed to be carried out during night or on Sundays or on authorized Holidays except when the work is unavoidable or absolutely necessary for safety of life or property of works, in which case the Contractor shall immediately inform the Engineer-in-charge accordingly in which case the contractor shall immediately inform the Engineer-in-charge accordingly.

4.16 Material obtained from Excavation

- 4.16.1 Material of any kind obtained from dismantling of a structure, excavation on the Site etc. shall remain the property of the DEI and shall be disposed off as the Engineer-in-charge may direct.

4.17 Treasure, Trove, Fossils, etc.

- 4.17.1 All fossils, coins, articles of value or antiquity, and structures and other remains or itmes of for a geological or archeological interest fount on the Site from dismantling of structure, excavation etc shall be placed under the care and authority of the DEI. The contractor shall take reasonable precautions to prevent Contractor's Personnel or other persons from removing or damaging any ot these findings. Incase where in the work or part thereof is suspended by the DEI for protection of such articles, then the sub-clause 7.9 (Suspension of work period up to 90 days) or sub-clause 7.10 (Prolonged Suspension of Work (Beyond 90 days) shall be applicable, as the case may be.

4.18 Site Drainage

- 4.18.1 All water which may accumulate on the Site during the progress of the works, or in trenches and excavated areas, from causes other than the Excepted Risks (as defined in the Definitions) shall be removed from the site to the satisfaction of the Engineer-in-charge and at cost of the contractor.

4.19 Protection of Trees

- 4.19.1 Trees designated by the Engineer-in-charge shall be protected from damage during the course of the works and earth level within 1 metre of each such tree shall not be changed where necessary, such trees shall be protected by providing temporary fending. Where tree uprooting is unavoidable, procedures as directed by the Engineer-in-charge shall be strictly complied with.

4.20 Security of the Site

- 4.20.1 The Contractor shall provide and maintain at his own expense all lights, guards, fencing, watch and ward when and where necessary or required by the Engineer-in-charge for protection of Materials and the works or for the safety and convenience of those employed on the works or the public.
- 4.20.2 The Contractor shall be responsible for keeping unauthorized persons off the site.

4.21 Co-operation and Facilities to other contractors

- 4.21.1 The Contract shall co-operate and share the Site with other Contractors, public authorities, utilities, and with the DEI as instructed by the Engineer-in-charge during the currency of the contract. The DEI may modify the schedule of work for other Contractors and shall notify the Contractor of any such modification.
- 4.21.2 The Contractor shall, in accordance with the requirements of the Engineer-in-charge, afford all reasonable facilities to other Contractors engaged contemporaneously on separate contracts. Similarly the departmental labour and labour of any other authorized agency or statutory body which may be employed or deployed at the Site for execution of any other work may also be extended co-operation and facility by the contractor.

4.22 Water Supply

Water shall be supplied free of cost to the Contractor at one point. All arrangements for storage and distribution of water shall be made by the contractor at his own cost.

4.23 Land

- 4.23.1 **Land for Contractor's office, Stores, Workshop etc** :The Engineer-in-charge shall, at his discretion and for the duration of the Contract, make available at site, land for construction of Contractor's field office, workshop, stores, assembling yard, etc required for execution of the Contract. Leveling and dressing of site, any construction of temporary roads, offices, workshops, etc. as per plan approved by the Engineer-in-Charge shall be done by the Contractor at his own cost.
- 4.23.2 **Land for Contractor's Colony** :Land will be given, if available, by the DEI for the Contractor's colony. Where even applicable the Contractor may indicated the requirement of land for the colony along with his tender. Land will be made available for the period of Contract. The

Contractor shall make his own arrangement for water supply, electric supply, sanitation, access road and general cleanliness of his colony. All these amenities shall be got approved by the Engineer-in-charge prior to construction of the camp. The contractor shall not permit any of his personnel to maintain any living quarters within DEI's land other than the land allotted for colony. In case the land allotted for setting up the camp/ colony is on lease, the contractor shall pay the appropriate municipal taxes / duties as applicable.

- 4.23.3 In respect of any land allotted to the Contractor for purposes of or in connection with the Contract, the Contractor shall be a licensee subject to the following and such other terms and conditions as may be imposed by licensor :-
- (a) that he shall pay a nominal license fee of Re. 1 per hectare per year or part of a year for use and occupation, in respect of each and every separate area of land allotted to him.
 - (b) That such use or occupation shall not confer any right of tenancy of the land to the Contractor.
 - (c) that the contractor shall be liable to vacate the land on demand by the Engineer-in-Charge.
 - (d) That the Contractor shall have no right to any construction over this land without the written permission of the Engineer-in-charge. IN case, he is allowed to construct any structure he shall have to demolish and clear the same before handing over the completed work unless agreed to the contrary.

On completion work, the Contractor shall handover the land duly cleaned to the Engineer-in-charge. Until and unless the Contractor has handed over the vacant possession of land allotted to him for the above purposes, the payment of his final bill shall not be made. The Contractor shall be made liable to pay at the rate of **Rs. 5,000 per week** as a penalty for the use and occupation of land beyond 6 months from the date of physical completion of work.

5 STAFF, LABOUR AND INDUSTRIAL SAFETY

5.1 Engagement of Staff and Labour

- 5.1.1 The Contractor shall not employ a person who has not completed eighteen years of age. He shall employ labour in sufficient numbers to maintain the required rate of progress and to complete the contract in the stipulated completion time. He shall engage skilled and experienced workmen to the satisfaction of the Engineer-in-charge to ensure workmanship as per the Contract.
- 5.1.2 The contractor shall, unless otherwise provided in the Contract, make his own arrangement for the engagement of all staff and labour (local or other) and for their payment, housing, catering, transport etc.
- 5.1.3 The contractor shall indemnify that the labour / workmen engaged by him are trained and certified for intended work.

5.2 Rate of Wages and Condition of Labour

- 5.2.1 The Contractor shall pay to labour employed by him either directly or through Sub-Contractors wages in accordance with the rules, regulations and the law in force relating to the payment of wages for the workers.
- 5.2.2 The Contractor shall pay not less than the minimum wages declared from time to time by CPWD / Govt.

5.3 Persons in the Service of DEI and other Contractors :

- 5.3.1 The Contractor shall not recruit, or attempt to recruit, staff and labour from amongst the DEI's Personnel without prior approval of Engineer-in-charge.
- 5.3.2 The Contractor shall not recruit, either on full-time or part time basis, the staff and labour from other Contractors, working with the DEI, without prior approval of Engineer-in-charge.

5.4 Labour Laws

- 5.4.1 The Contractor and his Sub-Contractors shall abide at all times by all existing labour enactment and rules, regulations, notifications, amendments and bye laws etc. issued by the State or Central Government or local administrative authorities applicable therein issued from time to time during the subsistence of contract. The Contractor shall keep the DEI indemnified, in case any action is taken against the DEI by the competent authority on account of contravention of any of the provision of any Act or rules made there under, regulations or notifications including amendments.
- 5.4.2 In the event of the Contractor committing a default or breach of any of the provision of the aforesaid Contractor's Labour Regulations as amended from time to time the DEI may impose penalty for each of such default as necessary. The Engineer-in-charge shall deduct such amount from bills or security deposit of the Contractor. The decision of the Engineer-in-charge in this respect shall be final and binding.
- 5.4.3 The employees of the Contractor and the Sub-Contractor in no case shall be treated as the employees of the DEI at any point of time.
- 5.4.4 List of some of the Major laws applicable to establishments engaged in building and other construction work are listed below. For details, latest version of relevant Acts and laws should be referred.
- Workmen Compensation Act, 1923
 - Payment of Gratuity Act, 1972
 - Employees P.F. and Miscellaneous Provision Act, 1952.
 - Maternity Benefit Act, 1951.
 - Contract Labour (Regulation & Abolition) Act.
 - Minimum Wages Act, 1948
 - Payment of wages Act. 1936
 - Equal Remuneration Act, 1979
 - Payment of Bonus Act, 1965
 - Industrial Disputes Act, 1947.
 - Industrial Employment's (standing orders) Act, 1946
 - Trade Unions Act, 1926
 - Child Labour (Prohibition & Regulation) Act 1986
 - Inter-State Migrant workmen's (Regulation of Employment & Conditions of services) Act, 1979
 - The Building and other construction workers (Regulation of Employment and conditions of service) Act, 1996 and the cess Act 1996
 - Factories Act, 1948
 - Employees State Insurance Act, 1948

- 5.4.5 The Engineer-in-charge shall have the powers to deduct any sum from the amount due to contractor for making good the loss suffered by worker(s) by reason of non-fulfillment of the conditions of contract or non-payment/short payment of wages or non-observance of the Labour Laws/regulations.
- 5.4.6 In every case in which by virtue of the provisions sub-sections (1) of Section 12, of the workmen's Compensation Act, 1923, the DEI is obliged to pay compensation to the workman employed by the Contractor, in execution of the works, the DEI without prejudice to its right under sub-section (2) of section 12 of the said act, shall be at liberty to recover such amount or any part thereof deducting it from the security deposit or from any sum due by the DEI to the Contractor whether under this contract or any other contract at the same unit.
- 5.4.7 The decision of the Engineer-in-charge in such matters based on reports from the inspecting officers as defined in the Contractor's labour Regulation as impendent to these conditions shall be final and binding and deduction (s) for recovery of such penalty may be made from any amount payable to the Contractor.

5.5 Facilities for Staff and Labour

- 5.5.1 Unless otherwise stated, the Contractor shall provide and maintain all necessary accommodation and welfare facilities for the Contractor's Personnel.

5.6 Health and Industrial Safety

- 5.6.1 The Contractor shall at all times take all reasonable precaution to maintain the health safety of the Contractor's Personnel. The contractor shall ensure firstaid facilities available at all times at the work site. Other facilities in collaboration with local health authorizes like medical staff, sick bay, ambulance, tec. Shall be provided as required. The Contractor shall also make suitable arrangement for necessary welfare and hygiene requirements and for the prevention of epidemics.
- 5.6.2 The Contractor shall provide mandatory Industrial Safety Training to all workmen. In case were it is specified in the schedule A, the same shall be provided by the DEI.
- 5.6.3 The Contractor shall provide and maintain all lights, fancing, guards, warning signs and caution board and similar items as required to ensure safe working condition at work site.
- 5.6.4 The Contractor and his Sub-Contractor shall comply with the instructions given by departmental safety officer or his representative(s) regarding safety precautions, protection measures and housekeeping, etc.
- 5.6.5 The Contractor shall provide proper access and working platforms for all place of work as per laid down standards or as advised by Engineer-in-charge.
- 5.6.6 The Contractor shall ensure all floor openings in his work are guarded / barricaded during the course of work ad at the end of each day's work.
- 5.6.7 The Contractor shall be held responsible for non-compliance of any of the safety measures, injuries, fatalities and compensation arising out of such situations or accidents.
- 5.6.8 Contractor shall be responsible for safety off all his employees during execution of the contract. As per Workmen's compensation Act, 1923 (Amended in 2000) the Contractor will ensure the

payment of compensation to his employees in case of an accident as early as possible within the time frame permitted by the law of land.

5.7 Contractor's Supervision for Compliance

- 5.7.1 The Contractor shall provide all necessary supervision of plan, arrange, direct, manage, inspect and test the work for acceptance by Engineer-in-charge through the execution of the works, and as long thereafter as is necessary to fulfill the contractor's obligation.
- 5.7.2 Supervision shall be done by a sufficient number of qualified persons having adequate knowledge of the language for communications (defined in sub-clause) 1.3 (Law and Language) and of the operations to be carried out (including the methods and techniques, required the hazards likely to be encountered and methods of preventing accidents) for the satisfactory and safe execution of the works.

5.8 Contractor's Personnel

- 5.8.1 The Contractor shall employ the key personnel as per the Schedule of Key Personnel as referred to at the time of submission of tender document to carry out or supervise the function stated in the Schedule or other personnel approved by the Engineer-in-charge. If the Contractor himself not have sufficient knowledge and experience to be capable of receiving instructions or cannot give his full attention to the works, the Contractor shall at his own expense, employ his accredited agent his own expense, employ his accredited agent as Site-in-charge approved by the Engineer-in-charge. The Engineer in charge shall have full powers to suspend execution of work in case of violation of this clause and the contractor shall be held responsible for such delay.
- 5.8.2 The Contractor's Personnel shall be appropriately qualified, skilled and experienced in their respective trades or occupations. The Engineer-in-charge may require the Contractor to remove (or cause to be removed) any person employed on the Site or Works, including the Contractor's Representative if applicable, who;
- (a) persist in any misconduct or lack of care.
 - (b) Carries out duties incompletely or negligently.
 - (c) fails to conform with any provisions of the contract, or
 - (d) persists in any conduct which is prejudicial to safety, health, or the protection of the environment.

The Contractor shall then appoint (or cause to be appointed) a suitable replacement person.

5.9 Records of Contractor's Personnel

- 5.9.1 The Contractor shall furnish to the Engineer-in-charge, fortnightly, a distribution return of the number and description by trades of the workers employed on the works. Along with this return, the Contractor shall also submit a statement of number of local people employed, to the Engineer-in-charge.
- 5.9.2 The contractor shall also submit on the 4th and 19th of every month to the Engineer-in-charge a true statement showing in respect of the preceding fortnight.
- (i) The accidents that occurred during the said fortnight showing the circumstances under which they happened and the extent of damage and injury caused by them and.
 - (ii) The number of female workers who have been allowed maternity benefit as provided in the Maternity Benefit Act, 1961 or Rules made there under and the amount paid to them.

5.9.3 The contractor shall submit the compliance report in the format appended.

5.10 Disorderly Conduct

5.10.1 The contractor shall at all times take all reasonable precaution to prevent any unlawful riotous or disorderly conduct by or amongst the Contractor's Personnel, and to preserve peace and protection of persons and property on and near the Site.

5.11 Other Compliance

5.11.1 The contractor shall fulfill and comply with all the requirements, if any, notified by the government or municipal authorities or agencies so authorized in this regard, in respect of supply of foodstuff, water and to take measures against insect & pest nuisance. Failure, on the part of the Contractor shall attract penalty in addition to the action as may be initiated by the state government or municipal authorities or agencies so authorized by the Government.

The contractor shall not do anything or permit its employees or worker deployed the site or office, which specifically or generally prohibited by law, rules or framed by the central or state government or municipal authorities.

The rules and regulations framed by the government authorized agencies, state or central government in regards to alcoholic liquor, Arms and ammunitions and the labor legislation shall be followed / complied in its letter & spirit, by the Contractor.

5.12 House Keeping

5.12.1 The contractor shall maintain the cleanliness of the work site and labour colony on a day to day basis. Failing to maintain cleanliness of work place, Engineer-in-charge will have full power to maintain the cleanliness at the risk and cost of the contractor.

6. PLANT, MATERIALS AND QUALITY ASSURANCE

6.1 Tools, Plants & Equipments

6.1.1 The contractor shall arrange at his own expense all tools, plant and equipment (hereinafter referred to as T&P) required for execution of the work.

6.2 Workmanship

6.2.1 The contractor shall execute the whole and every part of the work in the most substantial and workman like manner both as regards materials and otherwise in every respect in strict accordance with the specification. The contractor shall also confirm compliance to the design, drawing and instruction in writing in respect of the work to the Engineer-in-charge for his acceptance.

6.2.2 The works to be carried out under the Contract shall, except and otherwise provided in these conditions, include all labour, materials, tools, plant and equipment, and transport, which may be required in execution and completion of the works. The descriptions given in the Schedule of Quantities shall, unless otherwise state, be held to include waste on materials, carriage and cartage, carrying in return of empties, hoisting, setting, fitting and fixing in position and all other labour necessary in and for the full and entire execution and completion as aforesaid in accordance with good engineering practice and recognized principles.

- 6.2.3 In the case of any class or work for which there is no such specifications as referred to above, such work shall be carried out in accordance with Bureau of Indian Standards Specifications. In case there is no such specification in Bureau of Indian Standards, the work shall be carried out as per ASTM / BS or manufacture's specification. In case there are not such specifications as referred to the above the work shall be carried out in all respects in accordance with the instructions and requirements of the Engineer-in-charge.
- 6.2.4 The furnishing of engineering data by the contractor shall be in accordance with the schedule as specified in the technical specifications. The review of engineering data by the Engineer-in-charge shall not limit the Contractor towards any of his responsibilities and liabilities for mistakes and deviation, if any, from the requirement specified under these specifications and documents.
- 6.2.5 The Contractor shall carry out the manufacture of plant, the production and manufacturing of Materials, and all other execution of the Wroks.
- (a) In the manner (if any) specified in the Contract.
 - (b) In a proper workmanlike and careful manner, in accordance with recognized good practices, and with properly equipped facilities.

6.3 Material & Samples

- 6.3.1 The Contractor shall, at his own expense, provide all materials required for the works, other than that materials which are to be issued by the DEI.
- 6.3.2 The Contractor shall, at his own expense and without delay supply to the Engineer-in-charge samples in accordance with QA program of materials proposed to be used in the works. The Engineer-in-Charge shall, within 7 days of supply of samples or within such further period as he may require, intimate to the Contractor in writing, whether samples are approved by him or not. If samples are not approved, the Contractor shall forthwith arrange to supply to the Engineer-in-charge for his approval fresh samples complying with the specifications laid down in the Contract at his cost.

6.4 Inspection

- 6.4.1 The DEI's Personnel shall at all reasonable times:
- (a) Have full access to all parts of the Site and to all places from which natural materials are being obtained, and
 - (b) During production, manufacture and construction (at the Site and elsewhere), be entitled to examine, inspect, measure and test the materials and workmanship, and to check the progress of manufacture of plant and production and manufacture of Materials.
- 6.4.2 The Contractor shall give the DEI's Personnel full opportunity to carry out these activities including providing access, facilities, permissions and safety equipment along with required manpower. No such activity shall relieve the Contractor from any obligation or responsibility.
- 6.4.3 The Contractor shall give notice to the Engineer-in-charge whenever any work is ready and before it is covered up, put out of sight, or packaged for storage or transport. The Engineer- in- charge shall then either carry out the examination, inspection, measurement or testing without unreasonable delay, or promptly give notice to the Contractor that the Engineer-in-charge does

not require to do so. If the Contractor fails to give the notice, he shall, if and when required by the Engineer-in-charge uncover the work and thereafter reinstate and make good, all at the Contractor's cost.

6.5 Testing

- 6.5.1 The Sub-clause shall apply to all tests specified in the Contract.
- 6.5.2 Except as otherwise specified in the Contract, the Contractor shall provide all apparatus, assistance, documents and other information, electricity, equipment, fuel, consumables, instruments, labour, materials, and suitably qualified and experienced staff, as are necessary to carry out the specified test efficiently. The Contractor shall agree, with the Engineer-in-charge the time and place for the specified testing of any plant, Materials and other parts of the works.
- 6.5.3 The Engineer-in-charge shall give the Contractor not less than 24 hours' notice of the Engineer's intention to attend the tests. If the Engineer-in-charge does not attend at the time and place agreed, the Contractor may proceed with the tests, unless otherwise instructed by the Engineer-in-charge.
- 6.5.4 If the Engineer-in-charge requires this plant, Materials and workmanship to be tested in case of any doubt, the tests shall be repeated under the same terms and conditions. The cost of such additional tests shall be mutually agreed upon.

6.6 Rejection

- 6.6.1 The Engineer-in-charge shall have full powers to instruct the removal of any or all of the materials brought to Site by the Contractor which are not in accordance with the Contract specifications or do not conform in character or quality to samples approved by him. In case of default on the part of the Contractor in removing rejected materials, the Engineer-in-charge shall be at liberty to have them removed by other means. The Engineer-in-charge shall be at liberty to have them removed by other means. The Engineer-in-charge shall have full powers to procure other proper materials to be substituted for rejected material, in the even of the Contractor refusing to comply. All costs, which may accrue upon such removal and / or substitution shall be borne by the Contractor. The decision of Enigneer-in-Charge shall be final and binding.

6.7 Remedial Work

- 6.7.1 The Engineer-in-charge may instruct the Contractor to :
 - (a) remove from the Site and replace any plant or materials which is not in accordance with the Contract.
 - (b) Remove and re-execute any other work which is not in accordance with the Contract, and
 - (c) execute any work which is urgently required for the safety of the works, whether because of an accident, unforeseeable even or otherwise.
- 6.7.2 The Contractor shall comply with the Instruction within a reasonable time, or immediately if urgency is specified under sub-paragraph (c) above.
- 6.7.3 If the Contractor fails to comply with the instruction, the DEI shall be entitled to employ and pay other persons to carry out the work at the risk and cost of the Contractor.

6.8 Ownership of plant and Materials

- 6.8.1 Except otherwise specified in the contract, each item of plant and material shall, to the extent consistent with the Laws of the Country, become the property of the DEI at whichever is the earlier of the following times, free from liens and other encumbrances :
- (a) When it is incorporated in the Works.
 - (b) When the Contractor is paid the corresponding value of the Plant and Materials.
 - (c) When the secured advance is paid for materials received.
- 6.8.2 Material issued by the DEI to the Contractor for incorporation in the work either free of cost or chargeable basis shall remain the property of Corporation.

6.9 Octroi, Cess, Taxes, Royalties , etc.

- 6.9.1 All charges on account of octroi, cess, GST, royalty, and other duties on materials obtained for the works from any source (excluding materials supplied by the DEI) shall be borne by the Contractor.
- 6.9.2 In pursuant to or under any law, notification or order any royalty, cess or the like becomes payable by the DEI in respect of any material used by the Contractor in the works then in such a case the DEI shall be entitled to recover the amount paid in the circumstances as aforesaid from dues of the Contractor.
- 6.9.3 Any increase in rate of or new statutory levies, customs duty, GST, octroi and other duties during the currency of the contract shall be reimbursed by the DEI on submission of documentary proof for payments.

6.10. Urgent Works

- 6.10.1 If, by reason of an emergency arising in connection with and during the execution of the Contract, any protective or remedial work is necessary as a matter of urgency to prevent damage to the works, the Contractor shall immediately carry out such work.
- 6.10.2 If the Contractor is unable or unwilling to do such work immediately, the DEI may do or cause such work to be done as the DEI may determine is necessary in order to prevent damage to the works.
- 6.10.3 If the work done by the DEI was to be executed by the Contractor under the Contractor, the reasonable costs incurred by the DEI in connection therewith shall be paid by the Contractor to the DEI.

6.11 Material Issued by the DEI

- 6.11.1 Material to be supplied by the DEI are shown in Schedule B which also stipulates quantum, place of issue and rate(s) to be charged in respect thereof. The DEI shall, at its risk and cost, provided these materials at the time and place specified in the Contract. The Contractor shall then visually inspect them, and shall promptly give notice to the Engineer-in-charge of any shortage, defect or default in these materials. Unless otherwise agreed by both parties, the DEI shall immediately rectify the notified shortage, defect or default.
- 6.11.2 The Contractor shall bear the cost of loading, transporting to site, unloading, storing under cover as required assembling and joining the several parts together as necessary and incorporation

fixing materials in the works including all preparatory work of whatever description as may be required.

6.12 Material Accounting

- 6.12.1 The contractor shall account for all materials issued as free/ chargeable by the DEI. He shall also maintain account for the materials suggested by the Engineer-in-charge and procured by him. The material account must be submitted as and when required by the Engineer-in-charge and on completion of the contract. Retention money shall be released only after completion of material accounting.
- 6.12.2 The actual consumption of quantity of materials shall be calculated based on the measurement with reference to the standard formula / Bureau of Indian Standards/ approved cutting plan as applicable on the basis of drawing and specifications. The permissible returnable wastage and invisible wastage shall be as per Schedule 'B'.
- 6.12.3 The Contractor shall prepare and submit reconciliation statement indicating the quantities of material issued to him and / or procured by him and the quantities of material consumed as per design and drawing including permissible wastage to the satisfaction of the Engineer-in-charge with 15 days of the issue of written notice by him.
- 6.12.4 The Contractor shall be liable to be charged penalty in addition to the cost of material at market rate landing at DEI stores in case he fails to submit the reconciliation statement and / or deposit the excess material issued to him over the theoretical consumption including the permissible wastage back to the DEI stores.

7 COMMENCEMENT , DELAYS AND SUSPENSION

7.1 Commencement of work and completion time

- 7.1.1 The execution of the works shall commence from the date of commencement as mentioned in the work order and the completion period for the work shall also be reckoned from the said date. The time allowed for execution of the works or the extended time in accordance with these conditions shall be the **essence of the Contract**.
- 7.1.2 If the Contractor commits default in commencing the execution of the work as aforesaid; the DEI shall without prejudice to any other right or remedy be at liberty to forfeit the EMD.

7.2 Program

- 7.2.1 The contractor shall submit a detailed based time program for physical & financial progress of the works to the Engineer-in-charge for his approval, within 30 days after Commencement of works as defined in sub-clause 7.1 The Contractor shall also submit a revised program whenever the previous program is inconsistent with actual progress or with the Contractor's obligations.
- 7.2.2 Each program shall include :
- (a) the order in which the Contractor intends to carry out the works, including the anticipated timing of each stage or activity or milestone of design, submission of Contractor's Documents, procurement, manufacture of plant, delivery to site, construction, erection and testing including resource mobilization details.
 - (b) Sub Contractor wise detailed breakup of the above stages of work.

- (c) the sequence and timing of inspections and tests specified in the Contract, and
 - (d) a supporting report which includes :
 - (i) a general description of working methodology which the Contractor intends to adopt for the major stages/ activities, in the execution of the works, and
 - (ii) Contractor's resource mobilization details stating reasonable estimate of the number of each class of Contractor's personnel and of each type of Contractor's Equipment, required on the site for each major stage/activity.
- 7.2.3 The program shall define as mentioned above , intermediate milestones which will form the basis for, monitoring the progress and initiating such corrective measures as may be decided by the Engineer-in-charge which shall be final and binding.
- 7.2.4 Within 15 days of receipt of the program, the Engineer-in-charge shall give notice to the contractor, stating the extent to which the program does not comply with the contract. In absence of the same, the contractor shall proceed in accordance with the program, subject to his other obligation under the contract.
- 7.2.5 The DEI's Personnel shall be entitled to rely upon such program when planning their activities.
- 7.2.6 If, at any time, the Engineer-in-charge gives notice to the contractor that a program fails to comply with the contract or to be consistent with actual progress and the contractor's stated intentions, the contractor shall submit a revised program to the Engineer without any further delay.

7.3 Early Detection of Hindrances

- 7.3.1 The Contractor shall intimate the Engineer-in-charge at the earliest opportunity of specific likely future events or circumstances that may adversely affect the quality of the work, increase the contract price or delay the execution of works. The Engineer-in-charge may require the Contractor to provide an estimate of the expected effect of the event or circumstance on the Contract price and completion Date. The estimate is to be provided by the Contractor as soon as reasonably possible.
- 7.3.2 The information provided by the Contractor can be used by the Engineer-in-charge for considering his proposals to overcome the eventualities or reduce the effect on execution and completion of work as per contract conditions.

7.4 Hindrances

- 7.4.1 The contractor is required to record the hindrance if any, while carrying out the construction work as well as execution of the work in respect of design engineering, procurement and supply related issues, in the hindrance register maintained by the Engineer-in-charge. The contractor shall record hindrances in the Hindrance Register(s) and get it approved / endorsed by the Engineer-in-charge, as the case may be.
- 7.4.2 Hindrances recorded in the register shall form the basis for granting extension of time. The format of the hindrance register is annexed.

7.5 Rate of progress

7.5.1 The Contractor shall submit a report on the rate of progress of work at the desired frequency, as requested by engineer-in-charge.

(a) actual progress is too slow to complete within the Time of completions and / or

(b) progress has fallen or will fall behind the current program under sub-clause 7.2

Then the Engineer-in-charge may instruct the Contractor to submit the revised program, as envisaged in sub-clause 7.2 along with supporting report describing the revised methods which the Contractor proposes to adopt in order to expedite progress and complete the interim milestones as per the given schedule as well as complete the whole work within the time stipulated in the contract.

7.5.2 Unless the Engineer-in-charge notifies otherwise, the Contractor shall adopt these revised methods, which may require increases in the working hours and / or in the numbers of contractor's personnel and / or Goods, at the risk and cost of the Contractor.

7.6 Extension of Time for Completion

7.6.1 Request for extension of time, has to be made by the Contractor in writing within 15 days of the occurrence of the event causing delay. The Contractor shall indicate the period for which extension is desired, in such request.

7.6.2 All such events or requests shall be considered and analysed by the Engineer-in-charge within 30 days before completion period of the contract and the decision regarding the extension of time is to be communicated to the contractor before completion date.

7.6.3 The absence of any request or application from the Contractor for extension of time shall not be a bar for giving a fair and reasonable extension by the Engineer-in-charge and this shall be binding on the Contractor.

7.7 Compensation for Delay

7.7.1 Compensation for delay shall be levied in the contracts where the estimated cost put to tender is above Rs. 5 Lakhs.

7.7.2 If the Contractor fails to maintain the required progress or to complete the work and clear the site on the before the Contract or agreed extended date of completion, the Contractor shall, without prejudice to any other right or remedy of the Corporation on account of such breach, pay as agreed compensation amount calculated as stipulated below or such smaller amount as be fixed by the Corporation on the Contract value of the work for every week that the progress remains below that specified in contract document or that the work remains incomplete.

7.7.3 These delay damages shall be the amount calculated by the Corporation on the contract value of the work for every week that the progress remains below that specified in contract document or that the work remains incomplete.

7.7.4 The term 'Contract Value' shall be the value at contract rates of the work as ordered. This shall exclude the value of the part of works which has been taken over and put in use by the corporation.

7.7.5 The delay damages would be as follow :-

- (a) Completion period (originally stipulated) not exceeding 1 year – 1% of contract value per week.
- (b) Completion period (originally stipulated) exceeding 1 year - 0.5% of contract value per week.

7.7.6 However, the total amount due under his sub-clause shall not exceed 5% of the total value of the Contract value or of the contract value of the item or group of items of work for which a separate period of completion is specified.

7.7.7 These delay damages shall be the only damages due from the contractor for such default, other than in the event of terminated under clause 13 (Contract Termination by Corporation) prior to completion of works. These damages shall not relieve the Contractor from his obligation to complete the works, or from any other duties, obligations or responsibilities which he may have under the Contract.

7.7.8 The amount of compensation shall be adjusted or set off against any sum payable to he Contractor under this or any other contract (s) with same unit or any other unit (s) of the DEI.

7.8 Suspension of work for period upto 90 days.

7.8.1 The Engineer-in-charge may at any time instruct the Contractor to suspend progress of part or all the works. During such suspension, the Contractor shall protect, store and secure such part of all the works against any deterioration, loss or damage. No compensation shall be paid for suspension upto the period of 30 days.

7.8.2 The Contractor shall, on receipt of the order in writing of the Engineer-in-charge, suspend the progress of the work or any part thereof for such time and in such manner as the Engineer-in-charge may consider necessary for any of the following reasons.

- (i) on account of any default of the Contractor, or
- (ii) for proper execution of the works or part thereof reasons other than the default of the Contractor.

7.8.3 If the suspension is ordered for reasons (ii) above

- (i) Contractor shall be entitled to an extension of the time equal to the period of each such suspension plus 25% for completion of the item or group of items of work for which a separate period of completion is specified in the contract and of which the suspended work forms a part, and
- (ii) if the total cumulative period of all such suspension exceeds 30 days, the Contractor shall, in addition, be entitled to compensation for the period of suspension beyond 30 days, as mentioned in the Schedule A.

However the contractor shall submit within 10 days his claim to the Engineer-in-charge for every 15 days of suspension, over and above 30 days.

7.9 Prolonged Suspension of work (beyond 90 days)

7.9.1 If the works or part thereof is suspended on the orders of the Engineer-in-charge for more than 90 days at a time, except when suspension is ordered for reason 7.9.2 (i) above, the contractor

may after receipt of such order serve a written notice to the Engineer-in-charge requiring permission from him , to treat the suspension, where it affects only a prt of the works as deletion of such part and if the same is accepted by Engineer-in-charge then it will be dealt under Clause 11 (Variation and Adjustments) and no compensation on account of suspension shall be paid.

- 7.9.2 Where the suspension affect the whole of the works or part there of and the suspension of the part of the work is not treated as deleting as above, then the Contractor may serve a notice to Engineer-in-charge requiring permission within 10 days from the date of receipt of said notice by Engineer-in-charge to demobilize the labour/ staff and remove plant and equipment or any part thereof.
- 7.9.3 In case Engineer-in-charge agrees to the Contractor' request then the Contractor shall be at liberty to demobilize the labour/staff and remove plant and equipment or any part thereof hypothecated to the DEI under this contract to any other works site of the Contractor for carrying on his other works, after giving an undertaking through an indemnity bond to bring back to the site the labour/staff and plant and equipment as may be necessary for completion of the works, immediately after the suspension is revoked. If such plant and equipment are not brought back, the contractor shall forthwith repay the amount of the loan outstanding with interest. The security deposit from the contractor may also be forfeited.
- 7.9.4 In case the Engineer-in-charge does not agree to the contractor's request to demobilize, the contractor shall be continued to be pad the compensation as per sub-clause 7.9.3 (ii) provided the contractor submits his claim in accordance to the clause supported by details to the Engineer-in-charge.
- 7.9.5 In addition to above compensation the Contractor shall be entitled to an extension of the time equal to the period of such suspension plus 25% for completion of the item or group of items of work for which a separate period of completion is specified in the contract and of which the suspended work forms a part.

7.10 Payment for plant and Materials in Event of Suspension

- 7.10.1 The Contractor shall be entitled to payment of the value of plant and / or materials , meant to be incorporated in works which have not been delivered to site, if :
- (a) the work on plant or delivery of plant and / or Materials has been suspended for more than the 30 days except when suspension is ordered for reason 7.9.2 (i) above and
 - (b) the contractor has marked the Plant and / or Material as the Corporation's properly is accordance with the Engineer's instructions.

Under the above situation DEI shall make payment to the Contractor on production of documentary evidence to the effect that he has marked / purchase these items for DEI and make him responsible to deliver the se items to DEI either during suspension or after revoking suspension.

7.11 Resumption or Work

- 7.11.1 After the permission or instruction to proceed with the work is given, the contractor and the Engineer-in-charge shall jointly examine the works and the plant and materials affected by the suspension. The contractor shall make good any deterioration or defect in or loss of the works or

plant or materials, which has occurred during the suspension after receiving from the Engineer-in-charge an instruction to this effect.

8. DEI'S TAKING OVER

8.1 Completion Certificate

8.1.1 The Contractor shall as soon as the work is complete in all respect give notice to the Engineer-in-charge for his acceptance. The Engineer shall, within 30 days after receiving the Contractor's application :

- i) Shall inspect the work and shall furnish the Contractor with a certificate of completion indicating.
 - (a) Date of completion
 - (b) defects to be rectified by the Contractor and / or
 - (c) items for which payment shall be made at reduced rates.

When separate periods of completion have been specified for items or group of items, the Engineer-in-charge shall issue separate completion certificate for such item of groups of items.

- ii) reject the application, giving reasons and specifying the work required to be done by the Contractor to enable to completion certificate to be issued. The Contractor shall then complete this work before issuing a further notice under this sub-clause.

8.1.2 The contractor shall remove all the temporary material/equipment and clear the work place as per the directives of Engineer-in-charge. Contractor shall also ensure that all permanent structure has been adequately cleaned for use by other, failing which the Engineer-in-charge will have sufficient reasons to make the place good to use at the risk and cost of the contractor.

9. DEFECTS LIABILITY

9.1 Rectification of Defects

9.1.1 The defect liability period shall commence from the date of completion as certificated by the Engineer-in-charge. The Contractor shall be responsible to make good and rectify at his own expense within such period as may be stipulated by the Engineer-in-charge in his communication to contractor, any defect which may develop or may be noticed before the expiry of the defect liability period as mentioned in schedule (A).

9.1.2 The Contractor shall on receiving the intimation shall execute all work required to rectify defects or damage, as may be notified by the D.E.I., on or before the expiry date of the defects liability period for the works.

9.1.3 If the contractor fails to carry out the aforesaid work within the period fixed by the Engineer-in-charge after serving the notice to the Contractor, all work referred to in this Sub-clause shall be executed at the risk and cost of the Contractor.

9.1.4 The D.E.I. shall be entitled to an extension of the Defects Liability period for the works or a section of work for a period equal to the period during which the works or section of work cannot be used by the Corporation due to reasons of a defector by reason of a damage attributable to the Contractor.

- 9.1.5 Any rectification of defect which is not attributed to the Contractor but requested by the Engineer-in-charge for doing so, shall be carried out by the Contractor at the cost of DEI on the mutually agreed basis.

10. MEASUREMENT AND EVALUATION

10.1 Records & Measurement

- 10.1.1 Engineer-in-charge shall, except as otherwise stated, ascertain and determine by measurement the value of work done in accordance with the Contract.
- 10.1.2 Measurement shall be taken jointly by the Engineer-in-charge or his authorized representative and by the Contractor or his authorized representative from time to time.
- 10.1.3 Whenever the Engineer-in-charge requires any part of the Works to be measured, reasonable notice shall be given to the Contractor's Representative, who shall.
- (a) promptly assist the Engineer-in-charge in making the measurement along with a qualified official, and
 - (b) supply any particulars requested by the Engineer-in-charge appliance, labour and other things necessary for measurements.
- 10.1.5 Measurement shall be signed and dated by both the parties from time to time on the site during the progress of the Work.
- 10.1.6 If the Contractor objects to any of the measurement recorded on behalf of the DEI a notice to that effect shall be made with reasons and submitted to Engineer-in-charge for decision in this regard. After receiving that effect shall be made with reasons and submitted to Engineer-in-charge shall review the records and either confirm or vary them and certify the payment of the undisputed part. The decision of Engineer-in-Charge on such dispute or difference or interpretation shall be final and binding on both the parties.
- 10.1.7 If the Contractor fails to attend or send his authorized representative for measurement after such a notice or fails to counter-sign or to record his objection within a week from the date of measurement, then measurement taken by the Engineer-in-charge or by his authorized representative shall be taken to be the correct measurement of the work.
- 10.1.8 When the contract includes lump-sums in respect of parts of the work, the Contractor shall be entitled for payment in respect of such items of work involved or the part of the work in question, at the same lumpsum price as are payable under this contract for such items.
- 10.1.9 If in the opinion of the Engineer-in-charge, part of the work in question is not payable by measurement, the Engineer-in-charge may pay the amount commensurate to the value of work done based on lumpsum amount quoted. In such a case, the Engineer – in charge would provide a certificate which shall be final and conclusive against the Contractor with regard to any sum or sums payable to him under the provisions of the clause.
- 10.1.10 Recording of measurement will not relieve the Contractor of his responsibilities and liabilities over any recorded excess measurements or noticed defects till the completion of the defect liability period.

10.2 Method of Measurement

- 10.2.1 Except where any general or detailed description of the work in quantities expressly shows to the contrary, schedule of quantities shall be deemed to have been prepared and measurements taken in accordance with the procedure set forth in schedule of rates / specification no not withstanding any provision in the relevant standard method of measurement or any general or local custom.
- 10.2.2 In the case of items which are not covered by the Schedule of rates / specification, measurement shall be taken in accordance with the relevant standard Method of Measurement issued by the Bureau of Indian Standards and if for any item no such standard is available , then a mutually agreed method shall be followed

11. VARIATION AND ADJUSTMENTS

11.1 Right to Vary

- 11.1.1 Variation may be initiated by the Engineer-in-charge at any time prior to issuing the completion certificate for the works, by an instruction for the Contractor to submit a proposal. The Contractor shall submit a proposal for variation for approval of Engineer-in-charge.
- 11.1.2 Each Variation may include
- a) changes to the quantities of any item of work included in the Contract.
 - b) Changes to the quality and other characteristic of any item of work.
 - c) deletion of any work which forms part of the scope given in the contract, or
 - d) any additional work , plant, Materials and services necessary for the works, including any associated Tests on completion and exploratory work.
- 11.1.3 The time for completion of the works shall, in the event of variations resulting in additional cost over the Contract value being ordered be extended as follows, if requested by the Contractor;
- (a) in the proportion which the additional cost of the extra, additional or substituted work, bears to the original Contract sum; plus
 - (b) 25% of the time calculated in (a) above or such further additional time as may be considered reasonable by the Engineer-in-charge.

11.2 Payment of Variations

Quantities given in the Tender are tentative and may vary to any extent. Payment for additional quantities shall be at the contract rates and no claim for extra payments shall be entertained.

11.3 Contract Price Adjustment (NOT APPLICABLE FOR THIS WORK)

- 11.3.1 The rates quoted by the tenderer shall be the Base Price, which will be subjected or PRICE ADJUSTMENTS in accordance with the conditions and formula prescribed herein and further subject to satisfying the requirements specified in the clause only. This clause is applicable only to the contracts where stipulated completion period is more than 12 months.

11.3.2 For contract(s) where completion period as stipulated in NIT or work order is less than and upto 12 (twelve) months and where there is a delay which is attributed to the D.E.I. due to which the period of the contract exceeds 12 months, the contract price adjustments is applicable for the extended period. (for example, where the original contract period is 10 months and there is extension for 3 months, then adjustment is payable for one month i.e. 13th month only. However the subscript value of “0” defined in 11.3.4 below shall be the indices on the month in which the Mid period (50% in terms of days) of the extended contract period falls on.

11.3.3 The “Contract Price” as awarded shall be the Base Price, unless other wise specified.

A certain fixed percentage of the base price shall not be subject to any price adjustment. The balance percentage to be specified shall be of identified components towards Labour, Material(s) (not being material supplied / or services rendered at fixed prices by the DEI and P.O.L. and shall be subjected to price adjustment. The fixed component shall be 15% of the contract value, and is not subjected to price adjustments. However other components shall vary from contract to contract depending upon the scope of work (s) and this information is furnished by the DEI in Schedule A(refer clouse (11.3.4).

11.3.4 The actual amount price adjustment shall be determined by satisfying the conditions specified herein.

The price adjustment formula for the various components of the contact price shall be construed as stipulated hereinafter. The formula designed for governing and calculating the price adjustment to the applied to the contract price shall be as follows.

$$ACV1=CV(F+luxLu1/Luo+mxM1/M0)$$

Where :

ACV1 – Adjusted contract price i.e., value of work done after application of above price adjustment formula.

CV – Base contract price, subject to price adjustment, i.e. the value of the work done in the given period for which the Price Adjustment is to be calculated excluding cost of material supplied or service rendered at fixed prices by the DEI and the cost of extra items, rates for which have been worked out based on market rates.

F – Fixed component i.e. 15% of contract value, which is not subjected to any adjustment under this formula or otherwise.

Lu – Unskilled Labour component (Defined is Schedule A) expressed as percentage of thecontract value which will be subjected to adjustment.

Percentage of the contract value which will be subject to adjustment.

M, - Material component (bought by the contractor) expressed as percentage of the contract value (defined in schedule A), which will be subject to adjustment.

M, - Corresponding published price indices of material based on All India wholesale price index for individual commodities / Group items for the period under consideration published by Economic advisor to Government of India, Ministry of Industry & Commerce. Minimum wages in Rupees of a labour fixed under any law, statutory rule or order as applicable on

the last date of the month under consideration (where in subscript 'u' and 's' denotes the unskilled and skilled labour respectively)

SUBSCRIPT :

- '0' – refers to the value of the above – mentioned Minimum wages / material indices / petrol price applicable to previous month prior to the date of submission of the tenders (in case of two part tender the date of submission of part 1 shall be taken).
- '1' – refers to the value of corresponding Minimum wages, material indices / petrol price as applicable for the month prior to the month in which the work is executed for which adjustment is applicable, respectively.

- 11.3.5 The value of fixed component 'f' will remain unchanged and fixed and shall not be disputed.
- 11.3.6 Price Adjustment (s) shall be calculated for the quantum of works executed during the month of the bill.
- 11.3.7 Additional, altered or substituted items of work, derived from the agreed Bill of quantities and rates attached in work order will also attract price adjustment as per this clause. No price adjustment of the cost of material issued and / or services provided by the DEI shall be applicable, which are issued at fixed rates to the Contractor, Extra, altered or substituted item for which the rate has been derived from the market rate, shall not be subject to price adjustment within 12 month from the actual commencement of execution or date of its communication to the contractor whichever is earlier.
- 11.3.8 In the case of material brought to site for which any secured advance is included in the bill, the full assessed value of such advance shall be added to the cost of work shown in the bill for operation of this clause. Similarly, when such materials are incorporated in the work and secured advance is deducted from the bill, the full assessed value should be deducted from the cost of the work shown in the bill , running of final.
- 11.3.9 In case of advance payment is given for the work done but not measured the full value of such unmeasured work shall be added to the cost of work shown in the bill for operation of this clause. When such work is measured and paid the full value of such work shall be deducted from the cost of work shown in the bill, running or final.
- 11.3.10 Every month after the award of contract, the Contractor shall submit to the Engineer-in-charge, a written notice of the changes, if any , that have occurred in the specified indices of material / petrol prices and in minimum wages for labour during the previous month containing the effective date of such change, the extent of change etc. with authenticated documentary evidence (as described above) of the relevant published indices / petrol price / minimum wages to substantiate the price adjustment claim.
- 11.3.11 Provided further that such payment / refund shall not be operative and payable after the schedule expiry of the contract period including authorized extended contract period.
- 11.3.12 In case where the reasons for extension of the contract is attributable to the force majeure and contractor, the contractor shall be paid the contract price adjustment for the extended period at the frozen indices applicable for the month preceding to the last date of stipulated completion period or extended completion period attributable to DEI whichever is later, in case the

prevailing price indices are lower than the frozen indices, as stated above, the lower shall be considered.

11.3.13 For the purpose , the total delayed period shall be apportioned between delays due to the DEI force majeure events and / or the contractor in the following order :

1. Delay caused by the DEI will be allowed considering as if this delay due to the DEI happened first, immediately after stipulated contract completion period, irrespective of actual point in time in which such delay by DEI occurs.
2. Followed by delay due to Force Majeure.
3. Delay due to Contractor.

11.3.14 The total adjusted contract price shall be.
(sigma) ACV1 + Other elements of contract price, if any

11.3.15 Except as provided herein, no other expenditure incurred by the Contractor, under any clause (s)/ item (s) due to any reason what so ever , shall be payable to the contractor.

11.3.16 Bids specifying previous other than those specified above run the risk of rejection.

12. CONTRACT PRICE AND PAYMENT

12.1 Mobilization Advance

12.1.1 Mobilisation Advance shall be granted to the Contractor, if required by him, with the conditions mention herein being fulfilled.

12.1.2 Advance shall be granted where the estimated cost of work put to tender is Rs. 5 Crores or more.

12.1.3 The amount of mobilisation advance shall be limited to 10% of the contract value and shall be granted under following two categories:

- i) Lump sum Advance against a non-revocable Bank guarantee acceptable to the DEI which shall be 10% of the contract value.
- ii Over and above (i) an Advance at 90% of the purchase price of New Plant and Equipment acquired for the work and brought to site, against production of documents in support thereof and that such plant and equipment are hypothecated in favour of the DEI in the form required by the DEI. Further this new plant and equipment for which mobilisation advance applied for are not in excess of requirement and price thereof considered to be reasonable by the Engineer-in-Charge. (Subject to maximum of 5% of the contract value).

12.2 Payment of Running Bills

12.2.1 Running bills shall be submitted, monthly by the Contractor for the work executed during the previous month along with all supporting documents on the format prescribed by the DEI. The Engineer-in-charge shall then arrange to have the bill verified.

12.2.2 Payment of the Contractor's on account bill shall be made by the DEI within 25 days from the date of submission of the bill by the contractor along with all the supporting documents subject to the certification of the same by the Engineer-in-charge. If in the opinion of the Engineer-in-

charge it is likely to take more time for payment, an advance payment of 75% of the net bill amount shall be released to the contractor, within 3 working days and balance payment shall be released within 30 days from the date of submission of bills.

- 12.2.3 Any interim bill paid, relating to work done or materials delivered, may be modified or correct by any subsequent interim bills or by the final bill. Any certificate of the Engineer-in-charge supporting an interim payment shall not be conclusive evidence that any work or materials to which it relates is / are in accordance with the contract.

12.3 Over payments and Under Payments

- 12.3.1 Wherever any claim for the payment of a sum of money to the DEI arises under this contract against the Contractor, the same may be deducted from any sum due to the Contractor under this Contract or any other Contract with the DEI or from his security deposit; or he shall pay the claim on demand.
- 12.3.2 The DEI reserve the right to carry out post payment audit and technical examination of the final bill including all supporting vouchers. Abstract etc. The DEI further reserves the right to enforce recovery of any overpayment when detected, notwithstanding the fact that the amount of the final bill may be included by one of the parties as an item of dispute before the dispute resolution board for the contract.
- 12.3.3 If as a result of such audit and technical examination any overpayment is discovered in respect of any work done by the Contractor or alleged to have been done by him under the Contract, it shall be recovered by the DEI from the Contractor by any or all of the legal methods prescribed above. If any under – payment is discovered, the amount shall be duly paid to the Contractor by the DEI.
- 12.3.4 Provided that the aforesaid right of the DEI to adjust over payments against amount due to the Contractor under any other Contract with the DEI shall not extend beyond the period of three years from the date of payment of the final bill or in case the final bill is a MINUS bill, from the date the amount payable by the Contractor under the MINUS final bill is communicated to the Contractor.
- 12.3.5 Any amount due to the Contractor under this Contract for under – payment may be adjusted against any amount then due or which may at any time thereafter become due before payment is made to the Contractor, from him to the DEI on any Contract or account whatsoever.

12.4 Time limit for payment of Final bill

- 12.4.1 The final bill shall be submitted by the Contractor within 90 days of physical completion of the works payment of those items of the bill in respect of which there is no dispute and of items in dispute, for quantities and at rates as approved by the Engineer-in-charge, shall be made within the period specified hereunder. The Period shall be reckoned from the date of receipt of the bill by the Engineer-in-charge along with the all acceptable supporting documents.
- (i) If the tendered value of work is upto Rs. 1 Crores : 3 months
 - (ii) If the tendered value of work exceeds Rs. 1 Crores : 6 Months
- 12.4.2 The engineer-in-charge shall intimate for, if any, corrections in the final bill to Contractor. The contractor should re-submit the bill, with corrections within the 30 days of its return by the

Engineer-in-charge. The re-submitted bill will be checked and paid within the period as indicated in sub-clause 12.4.1(i) and (ii) above (as the case may be).

12.4.3 After payment of the amount of the final bills as aforesaid has been made, the Contractor may, if he so desires, reconsider his position in respect of the disputed portion of the final bill and if he fails to do so within 90 days, his disputed claim shall be dealt with as provided in the Contract.

13. CONTRACT TERMINATION BY DEI

13.1 Fore closure of contract

13.1.1 If at any time after acceptance of the tender / during execution of work the DEI shall decide to abandon or reduce the scope of the works for any reason whatsoever and hence not require the whole or any part of the works to be carried out, the Engineer-in-charge shall give notice in writing to that effect to the contractor and the Contractor shall have no claim to any payment of compensation or otherwise whatsoever, account of any profit or advantage which he might have derived from the execution of the works in full, but which he did not derive in consequence of the foreclosure of the whole or part of the works.

13.1.2 The contractor shall be paid at contract rates full amount for works executed at sit, on submission to the claim and review & approval of the claim by the Engineer-in-charge.

13.1.3 The DEI may in addition to above, compensate a reasonable amount to the contractor on mutual agreement basis based on submission of the claim and review of the claim by the Engineer-in-charge.

13.2 Determination / Cancellation of Contract

13.2.1 If the Contractor :

- (a) at any time makes default in proceeding with the works with due diligence and continues to do so after 7 days notice in writing from the Engineer-in-charge or
- (b) commits default in complying with any of the terms and conditions of the contract and does not remedy it or take effective steps to remedy in within 7 days after a notice in writing is given to him in that behalf by the Engineer-in-charge, or
- (c) fails to complete the works or items of work with individual dates of completion, on or before the date (s) of completion, and does not complete them within the period specified in a notice given in writing in that behalf by the Engineer-in-charge or
- (d) shall offer, or give or agree to give to any person in the DEI's service or to any other person on his behalf any gift, bribe, gratuity, commission, other thing of value or consideration of any kind as an inducement or reward for doing or forbearing to do or having done or forborne to do any act in relation to the obtaining or execution of this or any other contract for the DEI; or
- (e) shall enter into a contract with the DEI in connection with which commission has been paid or agreed to be paid by him or to his knowledge, unless the particulars of any such commission and the terms of payment there of have previously been disclosed in writing to the Accepting Authority/Engineer-in-charge; or

- (f) shall obtain a contract with the DEI as a result of wrong tendering or other non-bonafide methods of competitive tendering ; or
- (g) being an individual, or if a firm, any partner thereof, shall at any time be, adjudged insolvent or have a receiving order or order for administration of his estate made against him or shall take any proceedings for liquidation or amalgamation or reconstruction) under any insolvency Act for the time being in force or make any conveyance or assignment of his effects or composition or arrangement for the benefit of his creditors or purport so to do, or if any application be made under any insolvency Act for the time being in force for the sequestration of his estate or if a trust deed be executed by him for benefit of his creditors : or
- (h) being a company , shall pass a resolution or the court shall make an order for the liquidation of its affairs, or a receiver or manager on behalf of the debenture holder shall be appointed or circumstances shall arise which entitle the court or debenture holders to appoint a receiver a manager ; or
- (i) shall suffer an execution being levied on his goods and allow it to be continue for a period of 21 days ; or
- (j) assigns, transfers, sublets (engagement of labour on a piece-work basis or of labour with materials not to be incorporated in the work shall not be deemed to be subletting) or attempts to assign, transfer or sublet the entire works or any portion there of without the prior written approval of the Engineer-in-charge; or
- (k) indulges in criminal proceedings / activities with the employees of the DEI or any other sub contractor :
- (l) the engineer –in-charge may, upon giving 7 days’ notice to the Contractor, terminate the contract and expel the contractor from the site. The DEI’s election to terminate the contract shall not prejudice any other rights of the DEI, under the contract or otherwise.

13.2.2 The Engineer-in-charge shall on such determination/ cancellation have powers to :

- (a) take possession of the site and any materials, constructional plant, implements, stores, etc. Thereon ; and / or
- (b) carry out the incomplete work by any means at the risk and cost of the contractor.

13.2.3 On giving a notice to the Contractor, the Engineer-in-charge by virtue of the powers vested in him can ;

- (a) take possession of or
- (b) use as on hire

All or any tools, plants, materials and stores, in or upon the works or the site there of belonging to the contractor and intended to be used for the execution of the works or any part thereof.

The payments for the above would be as per the contract rates or in the case of these not being applicable, at current market rates to be certified by the Engineer-in-charge, whose certificate there of shall be final, and binding on the Contractor.

13.2.4 Otherwise the Engineer-in-charge may order the Contractor to remove such tools, plant, materials or stores from the premises. If the Contractor fails to comply with any such requisition, the Engineer-in-charge may remove them at the Contractor's expense or sell them on account of the Contractor and his risk in all respects.

In such case, the certificate of the Engineer-in-charge as to expenses of any such removal and the amount of the proceeds and expense of any such sale shall be final and conclusive against the Contractor.

13.2.5 On determination / cancellation of the Contract in full or in part, the Engineer-in-charge shall determine what amount, if any, is recoverable from the Contractor for completion of works or part of the works or in case the works or part of the works is not completed, the loss or damage suffered by the DEI. In determining the amount credit shall be given to the Contractor for the value of the work executed by him upto the time of cancellation, the value of Contractor's material taken over and incorporated in the work, and use of tools, tackles and machinery belonging to the Contractor.

13.2.6 Any excess expenditure incurred or to be incurred by the DEI in completing the works or part of the works or the loss or damage suffered or may be suffered by the DEI as are said after allowing such credit shall be recovered from any money due to the Contractor on any account , and if such money is not sufficient the Contractor shall be called upon in writing to pay the same within 30 days.

13.2.7 If the Contractor shall fail to pay the required sum within the aforesaid period of 30 days, the Engineer-in-charge shall have the right to retain any of all of the contractor's unused materials, construction plant, implements, temporary buildings etc. till the balance outstanding from the contractor is recovered in accordance with the provision of the Contract.

13.2.8 In the even of any one or more of the above courses being adopted by the Engineer-in-charge, the Contractor shall have no claim to compensation for any loss sustained by him by reasons of his having purchased or procured any materials or entered into any engagements or made any advances on account or with a view to the execution of the work or the performance of the contract. In case action is taken under any of the provision aforesaid, the contractor shall not be entitled to recover or be paid any sum for any work thereof or actually executed under this contract unless and until the Engineer-in-charge has certified in writing the performance of such work and the value payable in respect thereof and he shall only be entitled to be paid so certified.

13.2.8 Any sums in excess of the amount due to the DEI and unsold materials, construction plant, etc, shall be returned to the Contractor, provided, always that the cost or anticipated cost of completion by the DEI of the works or part of the works is less than the amount which the contractor would have been paid had the completed the works or part of the works, such benefit shall not accrue to the contractor.

13.2.9 In case any of the powers conferred upon the Engineer-in-charge by this clause become exercisable and the same are not exercised, the non exercise there of shall not constitute a waiver of any of the conditions hereof and such powers shall not with standing be exercisable in the event of any future case of default by the Contractor and the liability of the Contractor for compensation shall remain unaffected.

13.3 Termination of Contract on Death

- 13.3.1 If the Contractor is an individual or a proprietary concern and the individual or the proprietor dies and if the contractor is a partnership concern and one of the partners dies, then, unless the Engineer-in-charge is satisfied that the legal representative of the individual contractor or of the proprietor of the proprietary concern and in the case of partnership, the surviving partners, are capable of carrying out and completing the contract, the Engineer-in-charge shall be entitled to cancel the contract as to its incomplete part without the DEI, being in any way liable to payment of any compensation to the estate of the deceased Contractor and / or the surviving partners of the Contractor's firm on account of the cancellation of the contract.
- 13.3.2 The decision of the Engineer-in-charge that the legal representatives of the deceased contractor or the surviving partners of the Contractor's firm cannot carry out and complete the contract shall be final and binding on the parties in the event of such cancellation, the corporation shall not hold the estate of the deceased contractor and / or the surviving partners of the contractor's firm liable for damages for not completing the Contract.

14 RISK AND RESPONSIBILITY

14.1 Liability for damage, defects or imperfection and rectifications thereof

- 14.1.1 If the contractor or his workman or employees shall injure or destroy any part of the building in which they may be working or any building, road, fence, etc. contiguous to the premises on which the work or any part of it is being executed, or if any damage shall happen to the work while in progress, the Contractor shall, upon receipt of a notice in writing in that behalf make the same good at his own expense.
- 14.1.2 If it shall appear to the Engineer-in-charge or his Representative at any time during construction or re-construction or prior to the expiration of the Defects Liability Period, that any work has been executed with unsound, imperfect or unskilled workmanship or that any materials or articles provided by the Contractor for execution of the work are not in accordance with the contract, the contractor shall forthwith rectify or remove and re-construct the work so specified in whole or in part within the time limit specified by the Engineer-in-charge.
- 14.1.3 Failing which, the Engineer-in-charge may rectify or remove and re-execute the work and / or remove and replace with others, the materials or articles complained of, as the case may be, by other means at the risk and expense of the Contractor.
- 14.1.4 In such case the Engineer-in-charge may not accept the item of work at the rates applicable under the contract but may accept such items at reduced rates as the competent authority may consider reasonable during the preparation of on account bills or final bill if the item is so acceptable without detriment to the safety and utility of the item and the structure or he may reject the work outright without any payment.
- 14.1.5 In case of repairs and maintenance works, splashes and droppings from white wash in, painting etc. shall be removed and surfaces cleaned simultaneously with completion of these items of work in individual rooms, quarters or premises, etc. where the work is done, without waiting for completion of all other items of work in the contract. In case the Contractor fails to comply with the requirements of this clause, the Engineer-in-charge shall have the right to get the work done by other means at the cost of the contractor. Before taking such action however, the Engineer-in-charge shall give 3 days notice in writing to the contractor.

15 FORCE MAJEURE

15.1 Definition of Force Majeure

15.1.1 In this clause, "Force Majeure" means an exceptional even or circumstance ;

- a) which is beyond a party's control.
- b) which such party could not reasonably have provided against before entering into the contract.
- c) Which, having arisen, such party could not reasonably have avoided or overcome, and
- d) which is not substantially attributable to the other party.

Force Majeure may include , but is not limited to , exceptional event or circumstances of the kind listed below, so long as conditions, (a) to (d) above are satisfied;

- i. War, hostilities (whether was be declared or not), invasion, act of foreign enemies.
- ii. Rebellion , terroris, revaluation, insurrection, military or usurped power, or civil war.
- iii. Riot, commotion , disorder , strike or lockolut by persons other than the contractor's personnel.
- iv. Munitions of war, explosive materials, ionision radiation or contamination by radioactivity, except as may be attributable to the contractor's use of such munitions, explosives, radiation or radio-activity, and
- v. Natural catastrophes such as earthquake, hurricane, typhoon, tsunami or volcanic activity.

15.2 Consequence of Force Majeure

15.2.1 In the contractor is prevented from performing its substantial obligation under the contract by force majeure, and suffers. Delay and / or incurs cost by reason of such force Majeure, the Contractor may be eligible to

- (a) an extension of time for any such delay, if completion is or will be delayed under sub-clause 7.6 (extension of time for completion) and
- (b) if the event or circumstance is of the kind described in sub-paragraphs (a) to (d) of sub-clause 16.1 (Definition of force majeure) and , in the case of sub paragraphs (i) to (v) , occurs in the country , payment of any such costs of rectifying or replacing the works and / or Goods damaged or destructed by force Majeure, to the extent they are not indemnified through the insurance policy referred to in clause 15 (insurance)

15.2.2 The contractor shall, as may be directed in writing by the Engineer-in-charge, remove from the site any debris and so much of the works as shall have been damaged, taking to the DEI store such DEI T & P , articles and / or materials as may be directed.

15.3 Duty to Minimise Delay

15.3.1 The contractor shall , as may be directed in writing by the Engineer-in-charge, proceed with the erection and completion of the works under and in accordance with the provisions and conditions of the contract.

15.3.2 Each party shall at all times use all reasonable endeavours to minimize and delay in the executing of the contract as a result of Force Majeure. A party shall give notice to the other party when it ceases to be affected by the force Majeure.

16 CLAIMS, DISPUTES AND ARBITRATION

16.1 Contractor's Claims

16.1.1 The contractor may be granted extension of time and compensation under the following delay events, for the portion of delay attributable to DEI.

- (a) If the contractor suffers delay as a result of failure by the DEI to give right or possession of site as per the sub clause 2.1 (Possession of site).
- (b) If the contractor suffers delay from executing the work due to error or incorrect data furnished by the Engineer-in-charge, as per the clause 4.6 (setting out the work)
- (c) if there is a substantial delay in issue of drawings by the DEI and affects the progress of work.
- (d) if there is a substantial delay in issue of material agreed as per the contract to be supplied by DEI and effects the progress of work.

16.1.2 The contractor shall be eligible, based on reported and agreed delays attributable to the DEI, to extension of time for completion and addition for compensation for the same period which would be mutually agreed based on the initiation made by the contractor with proper supporting documents. The contractor shall serve an notice for claim with 90 days after circumstance, as stated under (a) to (d) above. The settlement of the claims shall be made at the end of the completion of contract.

16.1.3 If the Contractor fails to give notice of a claim with in period of 90 days, the Contractor shall not be eligible to additional payment, and the DEI shall be discharged from all liability in connection with the claim. Otherwise, the following provisions of this sub-clause shall apply.

16.1.4 The contractor shall keep such contemporary records as may be necessary to substantiate any claim, either on the site or at another location acceptable to the Engineer. Without admitting the DEI's liability, the Engineer-in-charge may, after receiving any notice under this sub-clause, monitor the record – keeping and / or instruct the contractor to keep further contemporary Records. The contractor shall permit the Engineer-in-charge to inspect all these records, and shall permit the Engineer-in-charge to inspect all these record, and shall (if instructed) submit copies to the Engineer-in-charge.

16.1.5 Within 15 days after the contractor gives notice, or within such other period as may be proposed by the contractor and approved by the Engineer-in-charge, the Contractor shall sent to the Engineer-in-charge a fully detailed claim which includes full supporting particulars of the basis of the claim if the event or circumstance given rise to the claim has a continuing effect.

- (a) this claim shall be considered as interim :
- (b) the contractor shall send further interim claims at monthly intervals, giving the accumulated delay and / or amount claimed, and such further particulars as the Engineer-in-charge may reasonability require ; and

- (c) the contractor shall send a final claim within 30 days after the end of the effects resulting from the event or circumstance, or within such other period as may be proposed by the contractor and approved by the Engineer-in-charge.

The Engineer-in-charge shall examine and accumulated all claims received under this clause , for settlement of the claim immediately after the close of the contract.

In case contractor , at the end of the contract, has dispute over the claim admitted by the Engineer-in-charge he may consider that the claim is rejected by the Engineer and any of the parties may refer it to the Dispute Board in accordance with sub-clause 17.4 (obtaining Dispute Resolution Board's Decision)

16.2 Dispute Resolution

- 16.2.1 Disputes if not resolved at the level of Engineer-in-charge , will be referred to a committee appointed by the Director DEI before the matter is referred to Dispute Resolution Board.

16.3 Appointment of the Dispute Resolution Board

- 16.3.1 The present sub-clause 16.3 and the forth coming sub clauses 16.4 , 16.5, 16.6 and 16.7 relating to appointment of dispute resolution board, obtaining Dispute resolution Board's decision, amicable settlement, Failure to comply to with Dispute resolution Board's decision and expiry of dispute resolution board's appointment shall not be applicable in respect in respect of a contract having the total value of less than Rs.1.00 crores at the time of award of contract. With a view to clarify the doubt, if any , it is declared that clause 17.3 to 17.7 shall be applicable in respect of the contract having value more than Rs. 1.00 crores. In purchases where the value of the contract is less than Rs. 1.00 crores, the disputes differences shall be settled and decided in accordance with clause 17.8 of this General conditions of contract.
- 16.3.2 If a dispute (of any kind whatsoever) arises between the parties in connection with, or arising out of, the contract or the execution of the works, including any dispute as to any certificate, determination instruction, opinion or valuation by the Engineer-in-charge, either party may refer the dispute inwriting to the Dispute resolution board for its decision, with copies to the other party.
- 16.3.3 The dispute resolution board (DRB) shall be established by signature of the Dispute Resolution Board Agreement (the board agreement) which shall be made effective from the same time as the signature of the contract agreement.
- 16.3.4 The board shall comprise three members experienced in the type of work involved and in the interpretation of document. One member shall be selected by each of the DEI and the contactor and approved by the other.
- 16.3.5 The third member shall be selected by the other two and approved by the parties. The third member shall sere as chairman of the board.
- 16.3.6 The terms of the remuneration of each of the three members, including the remuneration of any expert whom the dispute resolution board consults, shall be mutually agreed upon by the parties when agreeing the terms of appointment of the member or such expert (as the case may be). Each party shall be responsible for paying one-half of this remuneration.

16.3.7 In the event of death, disability, or resignation of any member, such member shall be replaced in the same manner as the member being replaced was selected. If for whatever other reason a member shall fail or be unable to serve, the chairman (or failing the action of the chairman then either of other members) shall inform the parties and such non-serving member shall be replaced in the same manner as the member being replaced was selected. Replacement shall be considered complete when the new member signs the board agreement. Throughout any replacement process the members not being replaced shall continue to serve and the board shall continue to function and its activities shall have the same force and effects as if the vacancy had not occurred.

16.4 Obtaining Dispute Resolution Board's Decision

16.4.1 The DRB shall be deemed to have received any reference on the date when it is received by the chairman of the DRB.

16.4.2 Both parties shall promptly make available to the DRB all such additional information, further access to the site, and appropriate facilities, as the DRB may require for the purposes of making a decision on such dispute. The DRB shall be deemed to be not acting as arbitrator (s).

16.4.3 If the dispute resolution board has given its decision as to a matter in dispute to both parties, and no notice of dissatisfaction has been given by either party within 30 days after it received the DRB's decision, then the decision shall become final and binding upon both parties.

16.4.4 Any dispute on which the board has not issued a recommendation within 30 days of its final hearing on the dispute, or regarding which the recommendation (s) are not accepted, may be referred in writing by either party to arbitration in accordance with this clause, by written notice to the other party with copies to the board, such notice shall state that it is being made pursuant to this clause and shall establish the entitlement of the party giving it to commence arbitration provided that no such arbitration may be commenced until such notice is given. Such reference shall be made within 15 days of receipt of the Board's recommendation (s) or within 15 days of the day on which said period of 30 days expired, as the case may be, failing which reference any recommendation (s) previously rejected or not accepted shall be deemed accepted despite such previous rejection or non-acceptance and shall be final and binding upon the parties.

16.4.5 All recommendations, which have become final and binding, shall be implemented by the parties forthwith; such implementation shall include any relevant action of the Engineer-in-charge.

16.4.6 Whether or not accepted or deemed accepted, all of the Recommendation shall be admissible in any subsequent dispute resolution procedure, including any arbitration or any litigation having any relation to the dispute or disputes to which the recommendations (s) related.

16.4.7 Unless the contract has already been repudiated or terminated, the contractor shall, in every case, continue to proceed with the works with all due diligence and the contractor and the (DEI) shall give effect forthwith to every decision of the Engineer-in-charge unless and until the same shall be revised, as hereinafter provided, in an arbitral award.

16.5 Amicable Settlement

16.5.1 Where notice of dissatisfaction has been given under Sub-clause 17.4 (obtaining dispute resolution board's decision) above, both parties shall attempt to settle the dispute amicably before the commencement of arbitration. However, unless both parties agree otherwise, arbitration may be commenced on or after the 30th day after the day on which a notice of dissatisfaction and intention to commence arbitration was given even if not attempt at amicable settlement has been made.

16.6 Failure to comply with Dispute Resolution Board's Decision

16.6.1 In the event that a party fails to comply with a final and binding DRB decision, then the other party may, without prejudice to any other right it may have, refer the failure itself to arbitration under sub-clause 17.8 (Arbitration). Sub clause 17.4 (obtaining Dispute Resolution board's Decision) and sub clause 17.5 (Amicable settlement) shall not apply to this references.

16.7 Expiry of Dispute Resolution Board's Appointment

16.7.1 If a dispute arise between the parties in connection with, or arising out of, the contract or the execution of the works and there is no DRB in place, where by reason of the expiry of the DRB's appointment of otherwise.

- (a) Sub-clause 17.4 (obtaining dispute resolution board's decision) and sub-clause 17.5 (Amicable settlement) shall not apply, and
- (b) the dispute may be referred directly to arbitration under sub-clause 17.8 (Arbitration)

16.8 Arbitration

16.8.1 Any dispute note settled amicably and in respect of which the DRB's decision has not become final and binding shall be finally settled by arbitration. Unless otherwise agreed by both parties :

- i) For contracts with domestic contractors, arbitration with proceedings conducted in accordance with the Indian Arbitration and conciliation Act, 1996
- a) All questions and disputes relating to the meaning of the specifications, designs, drawings and instruction herein before contained in this contract or as to the quality of the workmanship or materials used on the work or arising out of the terms and conditions of the contract whether during the progress of the work or after the completing or abandonment thereof, at the request of the aggrieved party in writing, shall be referred to the sole arbitration of the person and appointed by the Director, DEI in respect of the contracts entered for and on behalf of DEI by any officer / Authority of the DEI.
- b) When it appears to the person that exists an element of a settlement which may be acceptable to the parties, he shall submit them to parties or their observation. He may reformulate the terms of a possible settlement in the light of their observations.
- c) If the parties reach agreement of the dispute, they may draw up and sign a written settlement agreement. They may request the person to draw up or assist them in drawing up the settlement agreement.
- d) if settlement agreement shall have the same status and effect as if it is an arbitral award on agreed terms on the substance of the dispute rendered by an arbitral tribunal under section 30 of the Act.
- e) If a settlement does not appear possible, the person after consultation with the parties, will give a written declaration that further efforts at conciliation are no longer justified and the person proceedings are terminated.
- f) when conciliation proceedings have become in fraction or have been terminated, the party, which initiated the conciliation, shall refer the disputes for Arbitration. The reference to

arbitration should be made preferably within 30 days of the termination of conciliation proceedings.

- g) The arbitration shall be conducted in accordance with the Indian arbitration and conciliation Act, 1996 for contracts costing upto Rs. 1.0 crores , a sole arbitrator shall be appointed. For contracts costing over Rs. 1.0 crores, a committee of arbitrator, one to be by the owner and third arbitrator, who will act as a chairman but not as umpire, to be chosen jointly by the two nominees. The decision of majority of Arbitrators shall be final and binding on both parties.

17. SCHEDULES

SCHEDULE 'A'

S. No.	Clause Reference No.	ITEM	STIPULATION
1.	1.1.1	Accepting authority	Director, DEI
2.	2.1.3	Time by which possession of site will be given	10 days
3.	4.14.1	Availability of Electricity	Yes
4.	4.14.1	The rate at which electricity will be charged	Free of cost
5.	4.23.2	Availability of Departmental water supply	Yes
6.	4.23.2(i)	Water charges	Free of cost
7.	4.24.2	Land availability for contractor's colony	Yes
8.	9.1.1	Defect Liability Period	12 month
9.	12.1	Interest on mobilization advance	8%
10.	7.8	Compensation for suspension (entire work) beyond 30 days by the Engineer in charge (per day rate)	Rs.2000.00 per day

SCHEDULE 'B'

MATERIAL ISSUED TO THE CONTRACTOR

(The Engineer-In-Charge) to indicate permissible wastage before issue of tender duly approved by the Competent Authority)

Sl. No.	Particulars	Unit	Rate at which Material will be issued	Maximum invisible wastage (non-refundable)	Maximum permissible wastage (returnable in case of free issue)	Qty. to be issue (Approx.)
1	2	3	4	5	6	7
1.	Cement	M.T.	Rs.7000.00	-	3%	-
2.	Reinforcement Steel	M.T.	Rs.54000.00	-	5%	-
3.	Electrical wires, fittings etc		Free of Cost	-	-	-
4	Sanitary pipes, fittings etc.		Free of Cost	-	-	-

Signature of Issuing Officer :

Signature of Contractor

Date :

Date :

FORMAT FOR HINDRANCE RIGISTER

S. No.	Nature of Hindrance	Date of occurrence	Date of removal	Period of hindrance	Overlapping period if any	Net extension	Dated sign of contract or with name	Date of sign of Eng r. With name	Remarks.

18. CONTRACTORS LABOUR REGULATIONS AND FORMS

18.1 Definitions:

In these regulations, unless otherwise expressed or indicated, the following words and expressions shall have the meaning hereby assigned to them :

- (a) **“Workman”** means any person employed by the contractor, directly or indirectly through a sub-contractor, to do any skilled, semi-skilled or unskilled manual, supervisory, technical or clerical work for hire or reward, whether the term of employment are expressed or implied but does not include any person-
1. Who is employed mainly in managerial or administrative capacity ; or
 2. Who being employed in supervisory capacity draws wages exceeding five hundred rupees per mensem or exercise either by the nature of the duties attached to the office or by reason of powers vested in him functions mainly of managerial nature.
 3. Who is an out worker, that is to say, a person to whom any articles or material are given out by or on behalf of the principal employer to be made up, cleaned washed, altered ornamental finished, repaired, adopted or otherwise processed for sale for the purpose of the trade or business of the principal employer and the process is to be carried out either in the home of the out worker or in some other premises, not being premises under the control and management of the principal employer.
- (a) **“Fair Wage”** means wages, which shall include wages for weekly day of rest and other allowances, whether for time or piece work, after taking into consideration prevailing market rates for similar employments in the neighborhood but shall not be less than the minimum rates of wages fixed under the minimum wages Act.
- (b) **“Contractor”** for the purpose of these regulations shall include an agent or sub – contractor employing labour on the work taken on contract.
- (c) **“Inspecting officer”** means any labour Enforcement officer, or Assistant labour commissioner of the chief labour commissioner’s organization.
- (d) **“Form”** means a form appended to these Regulations.

18.2 Notice of commencement : The contractor shall, shall, within **SEVEN** days of commencement of the work, furnish in writing to the inspecting officer of the area concerned the following information :

- (a) Name and situation of the work.
- (b) Contractors name and address
- (c) Particulars of the Department for which the work is undertaken.
- (d) Name and address of sub-contractors as and when they are appointed
- (e) Commencement and probable duration of the work
- (f) Number of workers employed and likely to be employed.
- (g) ‘Fair wages’ for different categories of workers.

18.3 Display of notice regarding wages, weekly day of rest etc.

The Contractor shall, before he commences his work on contract display and correctly maintain and continue to display and correctly maintain in the clean and legible condition in conspicuous places on the works, notice in English and in the local Indian Language spoken by majority of worker, giving the rate of air wages, the hours of work for which such wages are payable, the weekly rest day workers are entitled to and name and address of the inspecting officer. The contractor shall send a copy each of such notices to the inspecting officers.

(a) Fixation of wage periods :

The contractor shall fix wage periods in respect of which wages shall be payable. No wage period shall normally exceed one week.

18.4 Payment of wages :

- (i) Wages due to every worker shall be paid to him direct. All wages shall be paid in current coins or currency or in both.
- (ii) Wages of every worker employed on the contract shall be paid where the wage period is one week, within Three days from the end of the wage period ; and in any other case before the expiry of the 7th day or 10th day from the end of the wage period.
- (iii) When employment of any worker is terminated by or on behalf of the Contractor, the wages earned by him shall be paid before expiry of the day succeeding the one on which his employment is terminated.
- (iv) Payment of wages shall be made at the work site on a working day except when the work is completed before expiry of the wage period, in which case final payment shall be made at the work site within 48 hours of the last working day and during normal time.

NOTE : The term 'working day' means a day on which the work on which labour is employed, is in progress.

18.5 Register of Workmen :

A register of workman shall be maintained in the Form appended to these regulations and kept at the work site or as near to it as possible, and relevant particulars of every workman shall be entered therein within THREE days of his employment. (Ref. appendix I)

18.6 Employment Card :

The contractor shall issue an employment card in the Form appended to these regulations to each worker on the day of work or entry into his employments. If a worker already has any such card with him issued by the previous employer, the contractor shall merely endorse that Employment Card with relevant entries. On termination of employment the Employment card shall again be endorsed by the contractor and returned to the worker (Appendix II)

Register of Wages etc:

- (i) A register of wages cum muster roll in the form appended to these regulations shall be maintained and kept at the work site or as near to it as possible (Appendix III)
- (ii) A wage slip in the Form appended to these regulations shall be issued to every worker employed by the Contractor at least a day prior to disbursement of wages. (Appendix IV)

Amendments :

Central Government may from time to time, add to or amend these Regulation and issue such directions as it may consider necessary for the proper implementation of these regulations or for the purpose of removing any difficulty which may arise in the administration thereof

Contract Labour (Regulation & Abolition) Act 1970

(Refer Clause 14 of Special Condition)

Application / Notices / returns to be sent to the Authorizes	Register's Records to be maintained	Notices to be displayed	Other Required
<p>1. From VI-A to the inspector with regard to the actual date of commencement/ completion of each contract work within 15 days. (Rule 25(2) (VIII)).</p> <p>2. Half yearly return in Form No. XXIV (in duplicate) latest by 30th July and 30th January of each year to be sent to the licensing officer (Rule 82)</p>	<p>1. Contractor must held valid licensed in Form (No. VI (Rule 25(1))</p> <p>2. Register of persons employed in for No. XIII (Rule 75)</p> <p>1 Master Roll in form XVI</p> <p>2 Register of wages in form XVII</p> <p>3. Register of deductions of damages or loss in Form XX</p> <p>4 Do fines in from XXI</p> <p>5. do advances in from XXVII</p> <p>6 Do O.T. in from XXVIII. (Rule 78 (1) (G) (I) (II) (III)</p> <p>All registers shall be preserved for 3 calendar year from the date of last entry (Rule 80(3)).</p> <p>Shall be a combined one in Form XVII where the wage period is fortnights or less.</p>	<p>1. Notice showing the wage period and the place and time of disbursement of wages at the place of work (Rule 71)</p> <p>2 Abstract of the Act and the Rule in English and Hindi and in the language spoken by the majority of workmen in such form as may be approved by the contract labour commissioner. (Rule-73)</p> <p>3 Display of similar notices, which are required to the displayed by the principal employer under rule 81.</p>	<p>1. Send to the Principal Employer a copy of notice showing wage period and the place and time of disbursement of wages, which the contractor is required to display as the place of work.</p> <p>2. Wage slips to be issued to the workmen in form XIX at least a day prior to the disbursement of wages where the wage period is one week or more (Rule 78 (1) (b)</p> <p>3. Employment card to be issued in form XIV to every workmen within three days of the employment (Rule 76).</p> <p>4. Disbursement of wages in the presence of authorized representative of principal employer (sec 2(3))</p> <p>Entries in the register of wages to be authenticated by the initials of the contractor or his representative and duly certified by the authorized representative of the Principal Employer (Rule 73 (1)(c)</p>

PROPOSED GUIDELINES FOR SAFETY PRECAUTION TO BE TAKEN BY THE CONTRACTOR (THESE ARE NOT EXHAUSTIVE)

- (i) Suitable scaffolds should be provided for workman for all works that cannot safely be done from the ground or from solid construction except such short period work as can be done safely from ladders. When a ladder is used an extra worker shall be engaged holding the ladders. When a ladder is used an extra worker shall be engaged holding the ladder and if the ladder is used for carrying materials as well, suitable footholds and handholds shall be provided on the ladder.
- (ii) Scaffolding or staging more than 300 mm above the ground or floor, swung or suspended from an overhead support or erected with stationary support shall have a guard rail properly attached, bolted braced and otherwise secured at least 900 mm high above the floor or platform of such scaffolding or staging and extending along the entire length of the outside and ends thereof with only such opening as may be necessary for the delivery of materials, such scaffolding or staging shall be so fastened as to prevent it from swaying from the building or structure.
- (iii) Working platform, gangways and stairways should be so constructed that they should not sag unduly or unequally and if the height of the platform or the gangway or the stairway is more than 3.6 meters above ground level or floor level, they should be closely boarded, should have adequate width and should be suitably fastened, as described in (ii) above.
- (iv) Safe means, of access shall be provided to all working platform and other working places. Adequate precautions shall be taken to prevent danger from electrical equipment. No materials on any of the sites of work shall be so stacked or placed as to cause danger or inconvenience to any person or the public. The contractor shall also provide all necessary fencing and lights to protect the public from accident, and shall be bound to bear the expenses of defense of every suit, action or other proceedings as law that may be brought by any person for injury sustained owing to neglect of the above precautions and to pay any damages and costs which may be awarded in any such suit, action or proceedings to any such persons or which may with the consent of the Contractor be paid to compromise any claim by any such person.
- (v) All trenches, 1.2 meters or more than in depth, shall at all times be supplied with at least one ladder for each 30 meters in length of fraction thereof. A ladder shall be extended from bottom of the trench to at least 900 mm above the surface of the ground.
- (vi) Use of hoisting machines and tackle including their attachment's, anchorage and supports shall conform to the following standard or conditions :
 - (1) (a) These shall be of good mechanical construction, sound material and adequate strength and free from patent defect and shall be kept in good working order.
 - (b) Every rope used in hoisting or lowering materials or as a means of suspension shall be of durable quality and adequate strength and free from patent defects.
 - (2) Every crane driver or hoisting appliance operator shall be properly qualified and no person under the age of 21 years should be in charge of any hoisting machine including any scaffold which or give signals to the operator.
- (vii) Notwithstanding the above clauses from (i) to (vi) nothing in these shall exempt the contractor from the operations of any law in force in the Republic of India.

Appendix – I

Register of workmen

(Regulation 7)

- i) Name and address of the Contractor _____
- ii) Number and date of contract _____
- iii) Name and address of the Department awarding the contract _____
- iv) Nature of the Contract and location of the work _____
- v) Duration of the contract _____

Sr. No.	Name and surname of the workers	Age & Age	Father's / Husband's Name	Nature of Employment & Designation	Permanent Home address of Employee (village, distt Thana)	Present Address	Date of Commencement of employment	Date of termination or leaving of employment	Signature or thumb impression of the employee	Remarks
1	2	3	4	5	6	7	8	9	10	11

Appendix - 2
EMPLOYMENT CARD
(Regulation 8)

- i) Name and Sex of the worker _____
- ii) Father's Husband's Name _____
- iii) Address _____
- iv) Age or Date of birth _____
- v) Identification mark _____
- vi) Name and sex of the worker _____

Particulars of next of kin (wife / husband and children, if any, or of dependent next of kin in case the worker has no wife / husband or child)

Name

Full Address of Dependent _____

(Specify, Village, Distt and State _____)

Sr. No.	Name and address of employer (specify whether a contractor or a sub contractor)	Particulars of location of work site and description of work done	Total period for which the worker is employed (from ____ to ____)	Actual number of days worked	Leave taken (No. days should be specified)	Nature of work done by the worker	Wage period	Wage rate within particulars of unit in case of piece work	Total wage earned by the worker during the period shown under col.5	Remarks	Signature of the employer
1	2	3	4	5	6	7	8	9	10	11	12

N.B. for a worker employed at one time piece work basis and at another on daily wages, relevant entries in respect of each type of employment should be made separately

Appendix – 3

REGISTER OF WAGES – CUM – MUSTER ROLL

(Regulation – 9)

- i) Name and Address of the contractor _____
- ii) Number and date of Contract _____
- iii) Name and address of the Department awarding the Contract _____
- iv) Nature of the contract and location of the work _____
- v) Duration of the Contract _____
- vi) Wage period _____

						Fair Wages Payable		Wages Paid		Overtime worked			Deduction from wages										
No.	Name and surname of the worker	Father's/ Husband Name	Sex	Designation / Nature of work	Daily attendance (No of Units 1,2,3, 5, 6, 7)	Total attendance	Basic	DA & other allowance	Basic	DA & other allowance	Date	No. o Hrs.	Overtime wages earned	Total wages paid	Fine	Deduction for Damage or loos	House Rent	Recovery of	Other deductions	Net wages payable	Date of payment	Signature / Thumb impression of worker	Remarks
1	2	3	4	5	6	7	8	9	10	11	12	13	14	15	16	17	18	19	20	21	22	23	24

Appendix – 4
WAGE SLIP
(Regulation 9)

- i) Name of the Contractor _____
- ii) Place _____

-
1. Name of the workers with father'/
husband's name :
 2. Nature of Employment :
 3. Wage Period :
 4. Rate of Wages Payable :
 5. Total attendance / Unit or work done :
 6. Date of which overtime worked :
 7. Overtime wages :
 8. Gross Wages Payable :
 9. Total Deductions (Indication nature of deduction) :
 10. Net Wages payable :
-

Contractor's Signature/
Thumb Impression

Employees Signature/
Thumb Impression

Appendix – 5

REGISTER OF FINES

Regulation No. 10 (vii)

Sr. No	Name	Father's/Husband's Name	Sex	Department	Nature and date of offence for fines imposed	Whether workman showed offence cause against fine for not, if so enter date	Rate of wages	Date and amount of fine imposed	Date on which fine realized	Remarks
1	2	3	4	5	6	7	8	9	10	11

Appendix – 6

3. REGISTER OF DEDUCTIONS FOR DAMAGES OR LOSS CAUSED TO THE DEI PERSONS BY THE NEGLIGENCE OR DEFAULT OF THE EMPLOYED

Regulation No. 10 (vii)

Sr. No.	Name	Father's/ Husband's Name	Sex	Department	Damage or loss caused with date	Whether worker showed cause against deducti on, if so enter date	Date & amount of deducti ons impose d	Number of install ment if any	Date on which total amount realize d	Remarks
1	2	3	4	5	6	7	8	9	10	11

22. DISPUTES RESOLUTION BOARD AGREEMENT

THIS AGREEMENT, made and entered into this _____ day of _____

2019 Between _____ (The DEI and _____

_____) (“the contractor”), and the disputes resolution Board
(‘the Board’) consisting of three Board Members

(1) _____

(2) _____

(3) _____

WITNESSETH, that

WHEREAS, the DEI, and the contractor have contracted for the construction of the

_____ (Project name)

_____ (the ‘contract’) and

WHEREAS, the contract provides for the establishment and operation of the board NOW THEREFORE, the parties hereto agree as follows :

1. The parties agree to the establishment and operation of the board in accordance with this board Agreement.
2. Except for providing the services required hereunder, the Board Members should not give any advice to either party concerning conduct of the works.

The Board Members :

- (a) Shall have no financial interest in any party to the contract, or a financial interest in the contract, except for payment for series on the board.
- (b) Shall have had no previous employment by or financial ties to, any party to the contract, except for fee based consulting services on other projects, all of which must be disclosed prior to appointment to the board.
- (c) Shall have disclosed in writing to the parties prior to signature of this Agreement any and all recent or close professional or personal or personal relationships with any director, officer, or employee of any party to the contract, and any and all prior involvement in the project to which the contract relates.
- (d) Shall not , while a Board member, be employed whether as a consultant or otherwise by either party to the contract, except as a Board members.
- (e) Shall not , while a board members, engage in discussion or make any agreement with any party to the contract, regarding employment whether as a consultant or otherwise either after the contract is completed or after services as a Board member is completed.
- (f) Shall be and remain impartial and independent of the parties and shall disclose in writing to the corporation, the contractor, and one another any fact or circumstances which might be such to cause either the DEI or the contractor to question the continued existence of the impartiality and independence required of board members.

Except for its participation in the Board's activities as provided in the contract and in this Agreement none of the employer, the contractor, the Nodal Officer or his nominee, and one another any fact or circumstances which might be such to cause either the Employer or the contractor to question the continued existence of the impartiality and independence required of board members.

The Contractor shall :

- a) Furnish to each board member one copy of all documents which the board may request including contract documents, progress reports, variation orders , and other documents, pertinent to the performance of the contract.
- b) In co-operation with the Employer, co-ordinate the site visits of the board, including conference facilities, and secretarial and copying services.

The board shall serve throughout the operation of the contract . It shall begin operation following execution of this agreement, and shall terminate its activities after issuance of the taking over certificate and the board's issuance of its recommendations on all disputes referred to it.

Board Members, shall not assign or subcontract any of their work under this Agreement.

The Board members are independent and not employees or agenst of either the Employer or the contractor.

The board members are absolved of any personal and professional liabilitys arising from the activities and the Recommendations of the board.

Fess and expenses of the board members(s) shall be agreed to and shared equally by the employer and the contractor. If the board requires special services, such as accounting, data research, and the like, both parties must agree and the costa shall be shared by them as mutually agreed.

Board site visit :

- (a) The board shall visit the site and meet with representatives of the employer and the contractor and at regular intervals, at times of critical construction events, and at the written request of either party. The timing of site visit, failing agreement shall be fixed by the board.
- (b) Site meeting shall consist of an informal discussion of the status of the construction of the works followed by an inspection of the works, both attended by personnel from the employer, the contractor.
- (c) If requested by either party or the board, the employer will prepare minutes of the meetings and circulate them for comments of the parties.

Procedure for disputes referred to the board :

- a) If either party objects to any action or inaction of the other party, the objecting party may file a written Notice of dispute to the other party stating that it is given pursuant to relevant clause and stating clearly and in detail the basis of the dispute.
- b) The party receiving the Notice of Dispute will consider it and respond in writing within 7 days after receipt.
- c) This response shall be final and conclusive on the subject, unless a written appeal to the response is failed with the responding party within 7 days of receiving the response. Both parties are encouraged to pursue the matter further to attempt to settle the dispute. When

it appears that the dispute cannot be resolved without the assistance of the board either party may refer the dispute to the Board by written request for recommendation to the board, and the other party stating that it is made pursuant to relevant clause.

- d) The request for recommendation shall state clearly and in full detail the specific issue of the dispute to be considered by the board.
- e) When a dispute is referred to the Board, and the Board is satisfied that the dispute required the Board's assistance, the Board shall decide when to conduct a hearing on the dispute. The Board may request that written documentation and argument from both parties be submitted to each Board Members before the hearing begins. The parties shall submit insofar as possible agreed statements of the relevant facts.
- f) During the hearing, the contractor and the employer, shall each have ample opportunity to be heard and to offer evidence. The Board's Recommendation for resolution o the dispute will be given in writing, to the Employer and the contractor as soon as possible, and in any even not more than 28 days after the Board's final hearing on the dispute.

Conduct of Hearings :

- a) Normally hearing will be conducted at the site, but any location that would be more convenient and still provide all required facilities and access to necessary documentation may be utilized by the Board. Private sessions of the Board may be held at any location convenient to the board.
- b) The Employer and the Contractor shall have representatives at all hearings.
- c) During the hearings, no Board Member shall express any opinion concerning the merit of any facet of the case.
- d) After the hearing are concluded, the Board shall meet privately to formulate its Recommendations. All board deliberations shall be conducted in private, with all individual views kept strictly confidential. The Board's Recommendations, together with an explanation of its reasoning shall be submitted in writing to both parties. The Recommendations shall be based on the pertinent contract provisions, applicable laws and regulations, and the facts and circumstances involved in the dispute.
- e) The board shall make effort to reach a unanimous recommendation. If this proves impossible, the majority shall decide, and the dissenting member any prepare a written minority report for submission to both parties.

If during the contract period, the DEI and the Contractor are of the opinion that the dispute resolution Board is not performing its functions properly, the DEI, and the Contractor may together disband the Disputes Resolution Board. In such an event, the dispute shall referred to Arbitration straight away.

The DEI and the Contractor shall jointly sign a notice specifying that the Board shall stand disbanded with effect from the date specified in the notice. The notice shall be posted by a registered letter with AD or delivery of the letter, even if he refuses to do so.

SECTION – V

SPECIFICATIONS

**ALL WORK SHALL BE CARRIED OUT AS PER CPWD
SPECIFICATIONS**

Note :

In case items which are not specified in the CPWD specifications, have to be executed, the manufacturer's recommendations as per the specifications laid down by the Engineer-in-charge and the relevant I.S. Codes shall be followed.

DAYALBAGH EDUCATION INSTITUTE
DAYALBAGH, AGRA 282005

Tender No. DEI/Works/KVL/2019-20/DR-07

SECTION – VI

TENDER DRAWINGS

All Tender Drawings are available

Detailed construction and structural drawings will be made available as and when required with the progress of work

Signature of Contractor

Seal

The strength, stability & serviceability of the structure shall be checked for all the loading conditions. The design shall be checked for all the loading conditions. The design shall be checked for all the loading conditions.

NOTES:
 1. The structure shall be checked for all the loading conditions.
 2. The structure shall be checked for all the loading conditions.
 3. The structure shall be checked for all the loading conditions.
 4. The structure shall be checked for all the loading conditions.
 5. The structure shall be checked for all the loading conditions.

ARCHITECT:
 M/S. SRI SRI ARCHITECTS,
 No. 3, Aditya Nagar, 1st
 Cross, 20, Venkateswara
 Sampige Hall Road,
 Bangalore - 560077,
 Karnataka
 Ph: 91-9845277268.

CLIENT:
 OIS (Deemed University), Agri
 Project name: Conference
 Hall, OIS (Deemed
 University), Agri

Revision: 01
 Drawing: DCI_CD1_LA31
 Ground floor Plan
 Drawn by: S
 Date: 24/01/2019
 Scale: 1/4" = 1' 0"

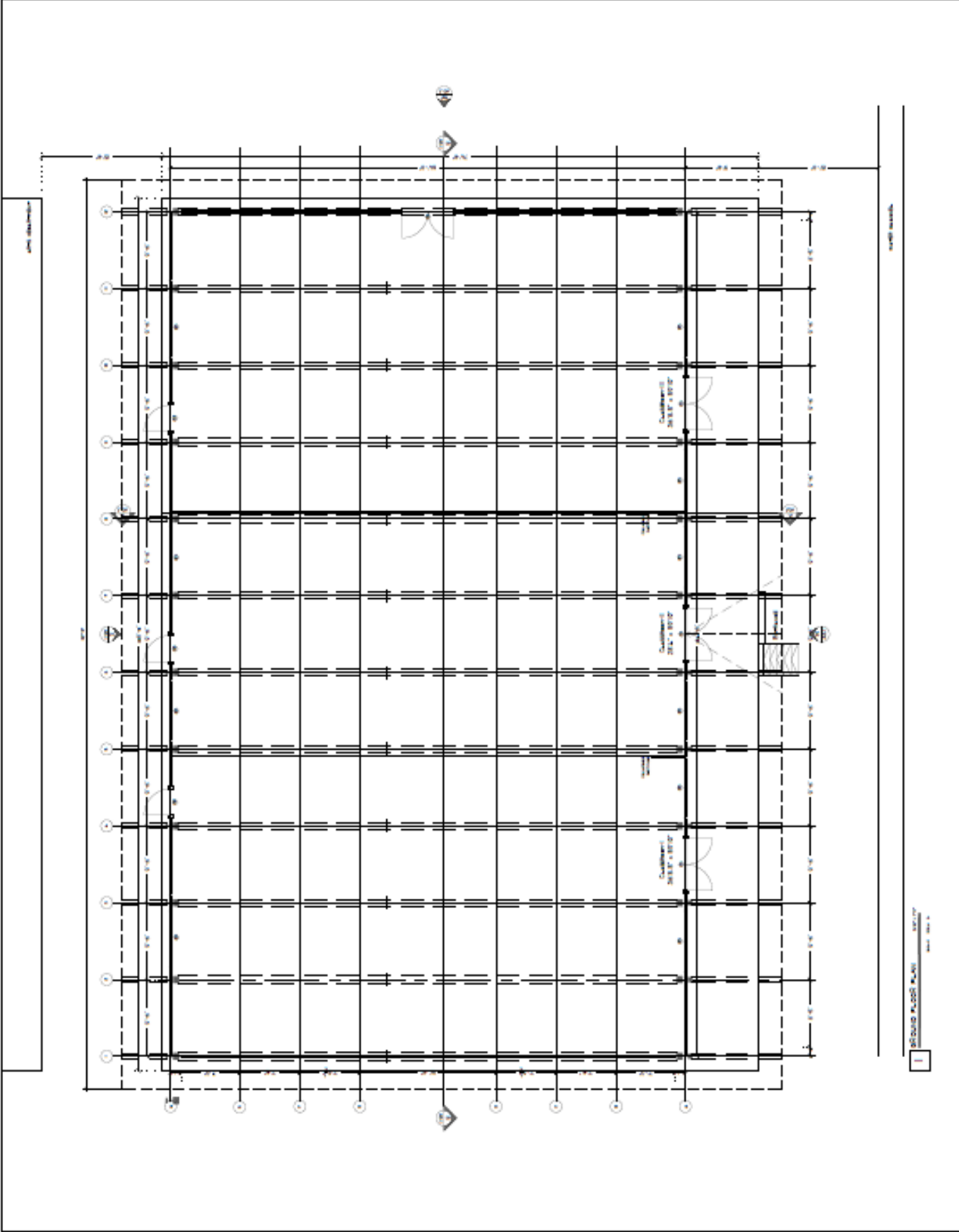

The Architect warrants that the drawings are prepared in accordance with the provisions of the Indian Contract Act, 1930, and shall be liable for the consequences thereof.

1. The drawings are to be used only for the project mentioned herein.

2. The drawings are to be used only for the project mentioned herein.

3. The drawings are to be used only for the project mentioned herein.

4. The drawings are to be used only for the project mentioned herein.

ARCHITECT:
MSY DESIGN ARCHITECTS
 20, Venkatesh Nagar,
 Bangalore - 560077,
 Karnataka
 Ph: 980-2779268.

CLIENT:
 Mr. Sameer
 Purnendu Graphics Pvt.Ltd.
 Project name: Terrace of
 Purnendu graphics

HALL-1

Revision: 00
 Drawing Code: COE_A11
 Drawing Date: 20/07/2018
 Drawing Scale: as per dwg

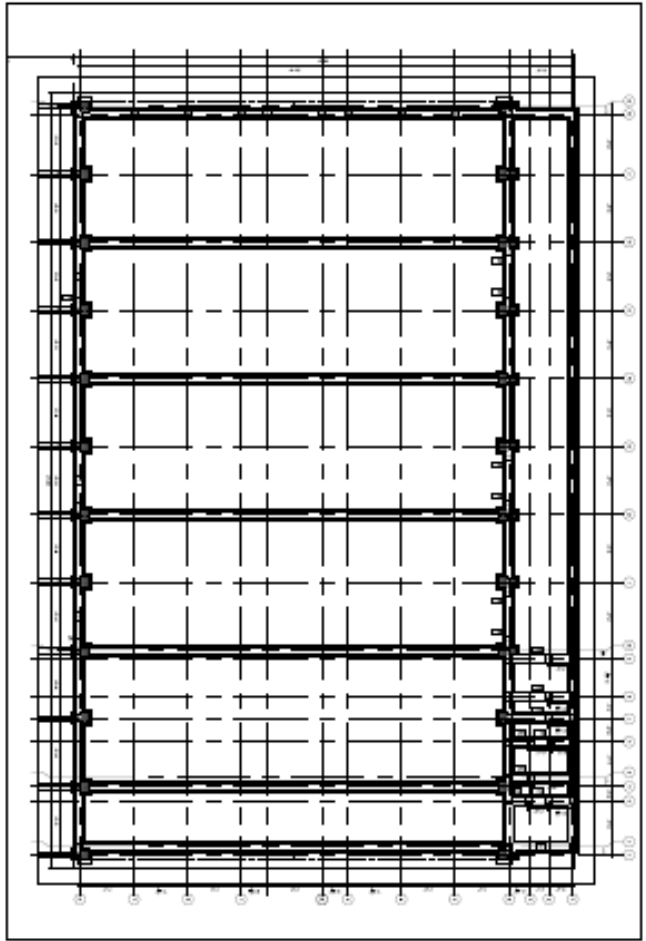

1 FOUNDATION PLAN
 SCALE: 1/4"

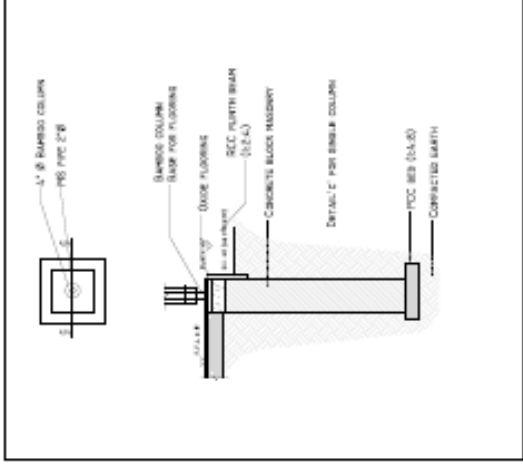
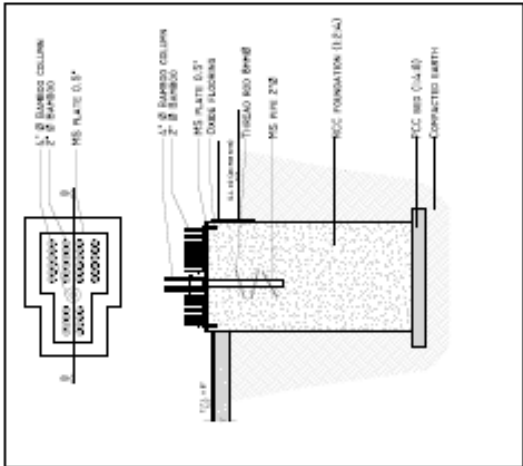
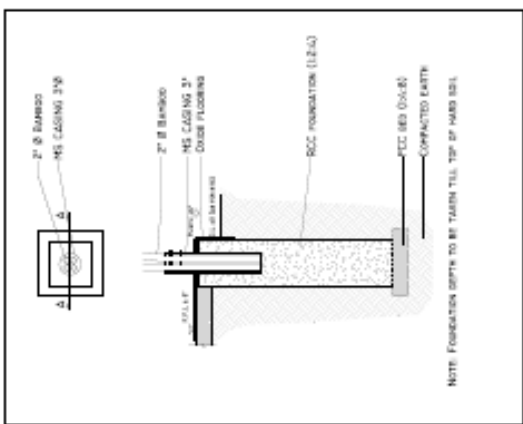

1. ALL DIMENSIONS ARE IN METERS UNLESS OTHERWISE SPECIFIED.
 2. ALL DIMENSIONS ARE TO FACE UNLESS OTHERWISE SPECIFIED.
 3. ALL DIMENSIONS ARE TO FACE UNLESS OTHERWISE SPECIFIED.
 4. ALL DIMENSIONS ARE TO FACE UNLESS OTHERWISE SPECIFIED.
 5. ALL DIMENSIONS ARE TO FACE UNLESS OTHERWISE SPECIFIED.

PROJECT:
ARCHITECTS:
 No. 1, Adisbrata
 20, Antaberna
 30, Antaberna
 40, Antaberna
 50, Antaberna
 60, Antaberna
 70, Antaberna
 80, Antaberna
 90, Antaberna
 100, Antaberna

CLIENT:
 DEDICATED UNIVERSITY AGO
 Project name: Carriera
 Project No: 101
 Project Address:
 University Ago

HALL-II

Revision: 01
 Drawing Code: C02_A12
 Date: 01/03/2019
 Scale: 1/40

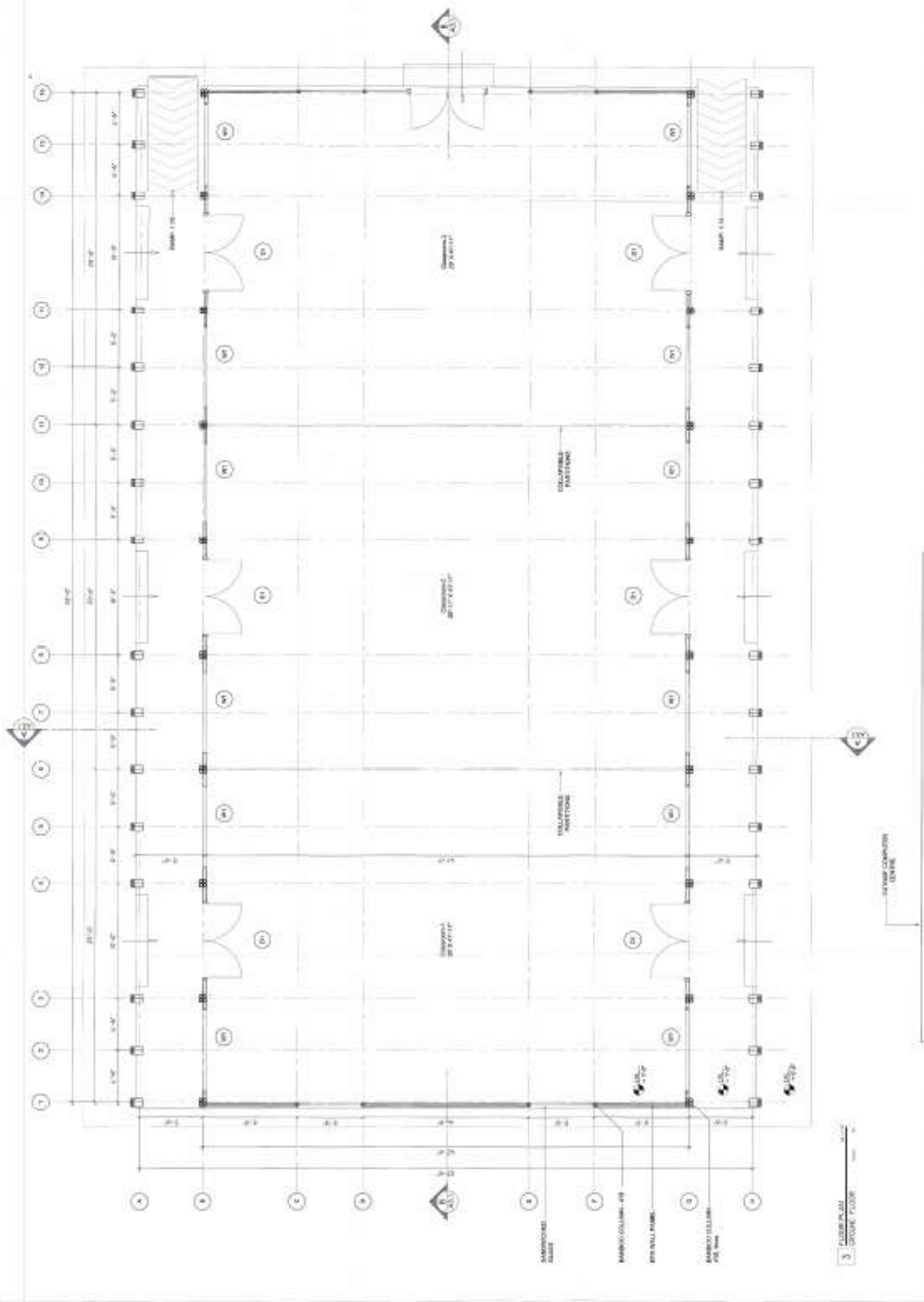

This drawing is the property of the architect and shall remain his/her property. It shall not be used for any other project without the written consent of the architect.

NOTES:
 1. All dimensions are in meters unless otherwise specified.
 2. All materials are to be of the best quality available.
 3. All work is to be done in accordance with the latest edition of the relevant codes and standards.
 4. The architect shall be responsible for the design and construction of the building.

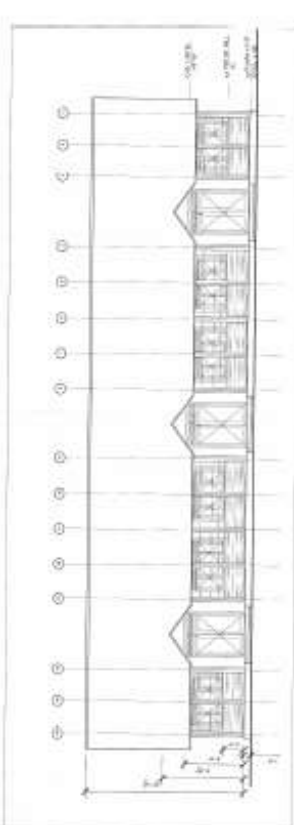
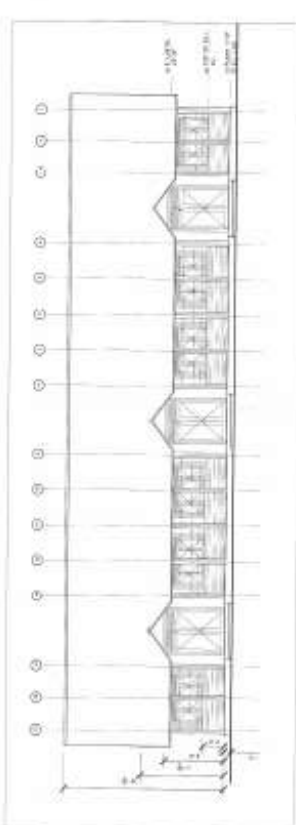
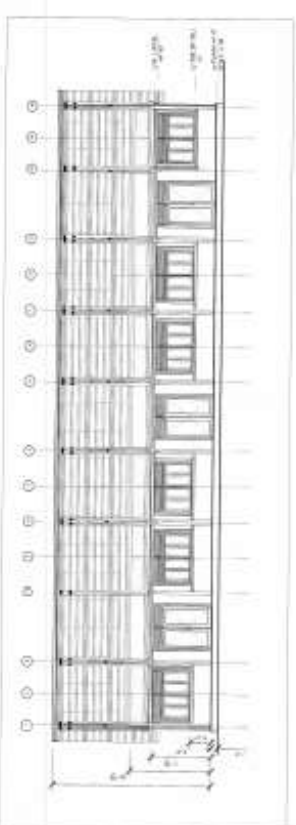
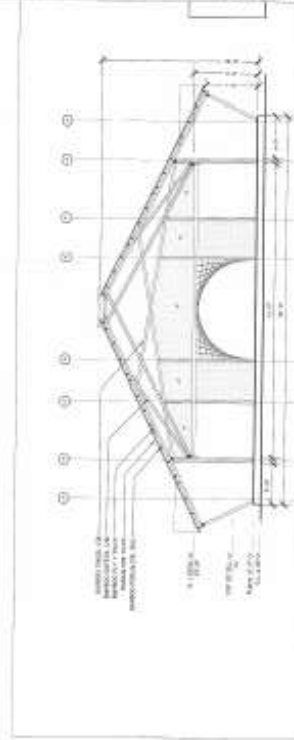
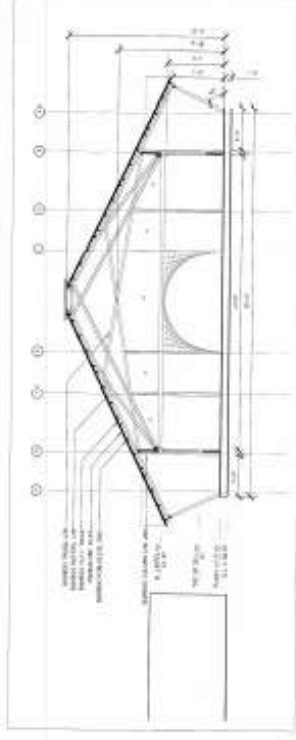

ARCHITECTS:
 MAHARAJAN ARCHITECTS
 No. 1, Adityanagar, No. 20,
 Periyar Nagar, No. 10,
 Kottayam, Kerala - 580077.
 Ph: 91-9847-2279558

CUSTOMER:
 CEI (Chennai University) - Agri
 Project name: Conference
 hall 3, CEI (Chennai)
 University - Agri

HAL - II
 Revision: 01
 Drawing: DO-CL-03-A3.1
 Section and Elevation
 Drawn by: RB
 Date: 04/03/19
 Scale: 1/4" = 1'-0"

DAYALBAGH EDUCATIONAL INSTITUTE

AGRA 282110

Name of work : Construction of Bamboo Hall No. – I and Bamboo Hall No. – II”

SECTION – VII

SCHEDULE OF MATERIALS TO BE SUPPLIED BY THE DEI

S. No.	Name of Material	Quantity	Unit	Rate
1.	Cement		M.T.	Rs.7000.00
2.	Reinforcement steel		M.T.	Rs.54000.00
3.	Electrical wires and fittings			Free of cost
4.	Water supply / Sanitary pipes and fittings			Free of cost

Signature of Contractor

Seal

DAYALBAGH EDUCATIONAL INSTITUTE
DAYALBAGH, AGRA 282110

Name of work : **Construction of Bamboo Hall No. – I and Bamboo Hall No. – II**

SECTION – VIII

SCHEDULE OF QUANTITIES OF WORKS

INSTRUCTION OF CONTRACTORS :-

1. The Description of items are to be read for the purpose of pricing in conjunction with ‘General Conditions of Contracts (Section-IV) for Works including Schedule ‘A’ , ,Special Conditions of Contracts (Section-III), Technical specifications (Section-V) and Schedule of tender drawings (Section-VI).
2. The prices quoted in the Schedule shall be inclusive of all values of the work described in including all costs and expenses which may be required for the construction maintenance / operation of the work together with all general risks, liabilities and obligations set forth of implied in the documents on which the tender is based.
3. The unit price quoted in the Schedule shall apply only to the actual quantities measured in the completed work in accordance with the specifications.
4. In case items not given in the schedule of quantities are required to be executed, the rates for the same shall be derived form the Delhi schedule of Rates 2016 with the appropriate enhancement. **Bidders should indicate the percentage above / below the DSR 2016 for computation of extra items.**
In case, the items are not available in the DSR 2016, the rates shall be determined based on market rates.
5. All tools, plant machinery, labour and materials required for satisfactory execution of work under this contract is to be supplied by the contractor and his rates should account for the same.
6. The tenderer shall fill in his rates in the schedule in figures and words both.
7. The contractor(s) shall make their signature (s) on each required places of tender after due study of the tender documents.

Date:

Signature of Contractor

Seal

NOTE :

Contractor must quote the rates in figures as well as in words for all items of work

Dayalbagh Educational Institute (Deemed to be University), Dayalbagh, Agra
Name of Work : Construction of Bamboo Hall No. -1 (North of Faculty of Arts) at DEI Agra

Schedule of Quantities

SI No.	Description of Items	Unit	Quantity	Rate in Figures	Rate in words	Amount
1	Earthwork					
1.01	Earth work excavation by mechanical/ manual means in all types of soil including dense soil, disintegrated/ weathered/ soft rock including necessary manual excavation for dressing the edges & leveling, all leads and lifts. Accordance with Lines, Lines, grades and curves shown on the plans or as directed by the Engineer in charge.Rate to include dewatering of both ground and surface water , removal of slurry generated while excavation if any and keeping the are free of water with necessary shoring, struting,required for keeping earth in position etc, excavating loose pockets and compacting the same	cum	150.90			
1.02	Earth work in filling to the foundationwith approved good quality new earth in plinth ,area development etc., whatever specified in layersof not exceeding 150mm thick including breaking clods,watering,compacting each layer with vibratory compactor and at un accessible places with wooden/steel rammers to achieve 95% proctor density at optimum moisture content,all leads and lifts, filling/pumping out of water to keep site dry while back filling ,cost includes conveyance of all materials, lanbor, machinery etc, complete as directed with available earth.	cum	48.68			

1.03	Providing and injecting Anti-termite treatment for pre construction Antitermite traetment and creating a continuous chemical barrier under and around the coloumn pits, wall trenches, junction of wall and floor,along the external perimeter of building ,expansion joints,over the top surface of consolidated earth on which apron is to be laid,surrounding of pipes and conduits etc by a speacialised approved agency, with a Gurantee for Ten years, etc.	sqm	743.49			
	Sub total for earthwork					
2	Concrete works					
2.01	Providing and placing cement concrete M10 (1:4:8) 100 mm thick with coarse graded aggregates of 20mm and down size, laid in layers and compacted by wooden or cast iron rammers including necessary shuttering, finishing ,curing etc by complete					
a	For foundtaion of walls,Below Footings and Below Plinth beams	cum	21.32			
b	For Below Floors, Pavements, Steps, etc;	cum	48.68			
2.02	Providing & Laying controlled reinforced cement concrete conforming to grades as specified in(IS 456-2000) as per specifications using 20mm down size aggregates at any depth or heights excluding the cost of steel reinforcement centering, shuttering,scaffolding but inclusive of cost towards compacting with vibrations,curing and hacking the exposed surfaces wherever required to receive plaster or floated steel trowelled surface whenever specified					
a	For Footing concrete	cum	9.49			
b	For Plinth beam	cum	10.42			
3	Form works					

3.01	Formwork shall be designed for rigidity,durability,strength,water tightness,easy removal etc.,Formwork designed with proposed materials (to be approved prior to making) shall be able to retain its shape ,line ,dimension, level within allowable limits of variations.Props shall be only steel props .Slab shuttering shall be in MS sheets and plywood .Beams,Coloumns,sheer wall,wall,Retaining wall etc.shall be in good quality plywood only.							
a	For Footing concrete	sqm	66.91					
b	For Plinth beam	sqm	192.84					
c	For Roof	sqm	878.25					
4	Steel Reinforcement and strutral steel Works							
4.01	Providing and fixing steel reinforcement for RCC including material,fabricating as per IS-2502,transporting,storing,decoiling,straighening,cutting, bending,spirally hooping and placing in position at all levels,including all labour, equipments,supplies,incidental,sampling(Bp-53/kg)	kgs	3,140.00					
4.02	Collecting and fixing MS pipe 50mm dia and 60mm long with 3nos of 8mm rod at regular interval to hold the pipe in foundations	kgs	72.00					
5	Masonry							
	Providing and constructing foundation with table moulded brick with a minimum crushing strength of 35kgs/sqcm in cement mortar 1:6,in substructure at all levels and heights complete as per notifications and drawing(Size of the Brick is 230x115x75mm)	cum	79.72					
6	Bamboo works							
6.01	Providing and fixing 50mm dia bamboos as truss - treated,finished with touchwood and fixed to MS casting ,5mm gauge and with 8mm thread rod when required as per design	m	14,027.4					

6.02	Providing and fixing 100 mm dia as column - treated, finished with external touchwood coat and fixed to 50mm dia MS pipe 90mm long, 16 gauge at bottom and bundled with 8mm thread rod when required with 8mm thread rod at 300mm c/c to hold the bamboo wall panel as per design.	m	153.96			
6.03	Providing and fixing 100mm dia bamboo as beam, lintel, sill & side support for doors and windows treated, finished with external touchwood coat as per architectural drawing.	m	267.07			
6.04	Providing and fixing 50mm dia bamboo treated and finished with external touchwood coat as Purlin & rafter over the truss as per architectural drawing.	m	4,457.0			
6.05	Providing and fixing bamboo splits of 25mm wide and 6-8 mm thk. Bamboo splits 1' c/c along the longer axis as beading to lay mangalore tiles as per design. Rates to include all necessary materials for fixing.	m	2,949.70			
6.06	Providing and fixing 50mm dia bamboo as façade support treated, finished with external PU coat and fixed to MS casing, 5mm gauge and with 8mm thread rod when required as per design.	m	1,051.80			
7 Wood Works						
7.01	Providing and fixing Salwood frames for Doors of Size 6'6" x 8'6" fixed to bamboo on sides and Bamboo lintel on top with MS hold fasts and with Double shutters with 3mm Bamboo ply as infill, frame of 6" x 1.5" shutter, top & bottom rail, Both shutter fixed to the frame with 4 nos SS hinges for each shutters; Rate to include finishing and also labour charges for fixing fixtures like locks, handles etc. - 5 no.	sqm	25.67			

7.02	Providing and fixing Salwood frames for Doors of Size 3'6"x8'6" fixed to bamboo on sides and Bamboo lintel on top with MS hold fast and with single shutters with 3mm Bamboo ply as infill, frame of 6"x1.5" shutter, top & bottom rail, Both shutter fixed to the frame with 4 nos of SS hinges for each shutters; Rate to include finishing and labour charges for fixing fixtures like locks, handles etc. -3 no.	sqm	7.80			
7.03	Providing and fixing window with Salwood frame of Size 3"x1.5" with 2 horizontal mullion inbetween and MS hold fasts embedded in cement concrete with double shutters 3"x1.5" with 6mm toughned glass as infill with wood lipping of standard size all round and fixed glass above and below; shutter fixed to the frame with 4 nos of SS hinges for each shutters; Rate to include finishing ans also labour charges for fixing fixtures like locks, handles etc.(7'2"x5'1") - 10 no.	sqm	37.17			
7.04	Providing mud crete wall system . Clay mixed with cow dung, straw to be plastered on both ides of bamboo split mesh (forming wall)and inner side to be cement plastered with jali cladding. Rate incudes all finishes ans labour charges for erecting, fixing fixtures etc.	sqm	175.18			
8	Finishing and flooring work					
8.02	Providing & laying oxide flooring in approved color as per drawing with over appropriate subfloor, finished etc., complete.	sqm	743.49			
9	Fabrication					
	Providing, supplying, fabricating and fixing works as per design drawings and details compolete including, welding, cutting, 2 coates of approved enamel painting etc. complete.	Kgs	180.36			
	Sub total for fabrication					
10	Painting and polishing					

10	Painting and polishing							
10.01	Providing and applying for all wooden surfaces with synthetic enamel paint of approved make and shade by sand papering the surfaces, removing dirt holes, cracks using wood filler and applying one coat of primer, water cutting the surface, applying touch up putty wherever required followed by spraying 2 coats of enamel.	sqm	175.18					
10.02	Providing and applying for all wooden surfaces with synthetic enamel paint of approved make and shade by sand papering the surfaces as directed, removing dirt, removing/making up dents, holes, cracks using wood sealer followed by 3 coats of melamine matt or glossy as directed	sqm	175.18					
11	Roofing							
11.01	Providing and laying Mangalore tile with single groove over bamboo splits 25mm wide and 6-8mm thk. over 1.5" dia bamboo purlin mounted over 3" dia bamboo rafters ;Rates including mangalore tiles, Purlin, rafters, Scaffolding etc.	sqm	904.50					
11.02	Providing and laying 3mm Bamboo ply as under roof fixed to 1.5" dia bamboo purlin, rates include bamboo ply fixing, scaffolding, and al fixtures.	sqm	9,732.00					
13	Glass work							
	Providing and fixing clear Glass of 6mm for façade, including cutting and all fixtures.	sqm	509.29					
14	Labour charges for internal electrification per sqm of the plinth area	sqm	692.00					
	TOTAL							

Dayalbagh Educational Institute (Deemed to be University), Dayalbagh, Agra
Name of Work : Construction of Bamboo Hall No. -2 (East of Computer Centre) at DEI Agra

Schedule of Quantities

Sl No.	Description of Items	Unit	Quantity	Rate in Figures	Rate in Words	Amount
1	Earthwork					
1.01	Earth work excavation by mechanical/ manual means in all types of soil including dense soil, disintegrated/ weathered/ soft rock including necessary manual excavation for dressing the edges & leveling, all leads and lifts. Accordance with Lines, Lines, grades and curves shown on the plans or as directed by the Engineer in charge. Rate to include dewatering of both ground and surface water , removal of slurry generated while excavation if any and keeping the are free of water with necessary shoring, strutting, required for keeping earth in position etc, excavating loose pockets and compacting the same	cum	69.37			
1.02	Earth work in filling to the foundation with approved good quality new earth in plinth , area development etc., whatever specified in layers of not exceeding 150mm thick including breaking clods, watering, compacting each layer with vibratory compactor and at un accessible places with wooden/steel rammers to achieve 95% proctor density at optimum moisture content, all leads and lifts, filling/pumping out of water to keep site dry while back filling , cost includes conveyance of all materials, labor, machinery etc, complete as directed with available earth.	cum	19.82			

1.03	Providing and injecting Anti-termite treatment for pre construction Antitermite treatment and creating a continuous chemical barrier under and around the column pits, wall trenches, junction of wall and floor, along the external perimeter of building, expansion joints, over the top surface of consolidated earth on which apron is to be laid, surrounding of pipes and conduits etc by a specialised approved agency, with a Guarantee for Ten years, etc.	sqm	476.30			
2	Concrete works					
2.01	Providing and placing cement concrete M10 (1:4:8) 100 mm thick with coarse graded aggregates of 20mm and down size, laid in layers and compacted by wooden or cast iron rammers including necessary shuttering, finishing ,curing etc by complete					
a	For foundation of walls, Below Footings and Below Plinth beams	cum	10.47			
b	For Below Floors, Pavements, Steps, etc;	cum	26.05			
2.02	Providing & Laying controlled reinforced cement concrete conforming to grades as specified in (IS 456-2000) as per specifications using 20mm down size aggregates at any depth or heights excluding the cost of steel reinforcement centering, shuttering, scaffolding but inclusive of cost towards compacting with vibrations, curing and hacking the exposed surfaces wherever required to receive plaster or floated steel trowelled surface whenever specified					
a	For Footing concrete	cum	6.23			
b	For Plinth beam	cum	9.91			
3	Form works					

3.01	Formwork shall be designed for rigidity,durability,strength,water tightness,easy removal etc.,Formwork designed with prosed materials (to be approved prior to making) shall be able to retain its shape ,line ,dimension, level within allowable limits of variations.Props shall be only steel props .Slab shuttering shall be in MS sheets and plywood .Beams,Coloumns,shear wall,wall,Retaining wall etc.shall be in good quality plywood only.						
a	For Footing concrete	sqm	69.75				
b	For Plinth beam	sqm	83.64				
c	For Roof	sqm	618.03				
4	Steel Reinforcement and strutral steel Works						
4.01	Providing and fixing steel reinforcement for RCC including material,fabricating as per IS-2502,transporting,storing,decoiling,starightening,cutting, bending,spirally hooping and placing in position at all levels,including all labour, equipments,supplies,incidenrtals,sampling(Bp-53/kg)	kgs	2,670.00				
4.02	Collecting and fixing MS pipe 50mm dia and 60mm long with 3nos of 8mm rod at regular interval to hold the pipe in foundations	kgs	72.00				
5	Masonry						
	Providing and constructing foundation with table moulded brick with a minimum crushing strength of 35kgs/sqcm in cement mortar 1:6,in substructure at all levels and heights complete as per notifications and drawing (Size of the Brick is 230x115x75mm)	cum	41.34				
6	Bamboo works						
6.01	Providing and fixing 50mm dia bamboos as truss - treated,finished with touchwood and fixed to MS casting ,5mm gauge and with 8mm thread rod when required as per design	m	2,134.2				

6.02	Providing and fixing 100 mm dia as coloumn - treated, finished with external touchwood coat and fixed to 50mm dia MS pipe 90mm long ,16 gauge at bottom and bundled with 8mm thread rod when required with 8mm thread rod at 300mm c/c to hold the bamboo wall panel as per design.	m	582.30			
6.03	Providing and fixing 100mm dia bamboo as beam, lintel, sill & side support for doors and windows treated ,finished with external touchwood coat as per architectural drawing.	m	259.15			
6.04	Providing and fixing 50mm dia bamboo treated and finished with external touchwood coat as Purfin & rafter over the truss as per architectural drawing.	m	2,048.8			
6.05	Providing and fixing bamboo splits of 25mm wide and 6-8 mm thk. Bamboo splits 1' c/c along the longer axis as beading to lay mangalore tiles as per design.Rates to include all necessary materials for fixing.	m	1,875.00			
6.06	Providing and fixing 50mm dia bamboo as façade support treated, finished with two or more coats of touchwood and fixed to MS casing, 5mm gauge and with 8mm thread rod when required as per design.	m	350.61			
7 Wood Works						
7.01	Providing and fixing Salwood frames for Doors of Size 6'6"x8'6" fixed to bamboo on sides and Bamboo lintel on top with MS hold fasts and with Double shutters with 3mm Bamboo ply as infill, frame of 6"x1.5" shutter, top & bottom rail, Both shutter fixed to the frame with 4 nos SS hinges for each shutters; Rate to include finishing and also labour charges for fixing fixtures like locks, handles etc. - 6 no.	sqm	27.88			

7.02	Providing and fixing window with Salwood frame of Size 3"x1.5" with 2 horizontal mullion inbetween and MS hold fasts embedded in cement concrete with double shutters 3"x1.5" with 6mm toughned glass as infill with wood lipping of standard size all round and fixed glass above and below; shutter fixed to the frame with 4 nos of SS hinges for each shutters; Rate to include finishing ans also labour charges for fixing fixtures like locks, handles etc.(7'2"x5'1") - 12 no.	sqm	44.05			
7.04	Providing mud crete wall system . Clay mixed with cow dung, straw to be plastered on both ides of bamboo split mesh (forming wall)and inner side to be cement plastered with jali cladding. Rate incudes all finishes and labour charges for erecting, fixing fixtures etc.	sqm	150.56			
8	Finishing and flooring work					
8.02	Providinig & laying oxide flooring in approved color as per drawing with over appropriate subfloor, finished etc., complete.	sqm	449.81			
9	Fabrication					
	Providing, supplying, fabricating and fixing works as per design drawings and details compolete including, welding, cutting, 2 coates of approved enamel painting etc. complete - I.S.	Kgs	150.00			
10	Painting and polishing					
10.01	Providing and applying for all wooden surfaces with synthetic enamel paint of approved make and shade by sand papering the surfaces, removing dirt holes, cracks using wood filler and applying one coat of primer, water cutting the surface, applying touch up putty wherever required dollowed by spraying 2 coats of enamel.	sqm	150.56			

10.02	Providing and applying for all wooden surfaces with synthetic enamel paint of approved make and shade by sand papering the surfaces as directed, removing dirt, removing/making up dents, holes, cracks using wood sealer followed by 3 coats of melamine matt or glossy as directed.	sqm	150.56			
11	Roofing					
11.01	Providing and laying Mangalore tile with single groove over bamboo splits 25mm wide and 6-8mm thk. over 1.5" dia bamboo purlin mounted over 3" dia bamboo rafters ;Rates including mangalore tiles, Purlin, rafters, Scaffolding etc.	sqm	618.03			
11.02	Providing and laying 3mm Bamboo ply as under roof fixed to 1.5" dia bamboo purlin, rates include bamboo ply frame, scaffolding and all fixtures.	sqm	618.03			
13	Glass work					
	Providing and fixing clear Glass of 6mm for facade, including sabbins and all fixtures.	sqm	155.20			
14	Labour charges for internal electrification per sqm of the plinth area	sqm	437.50			
	TOTAL					

TOTAL COST OF HALL - I and HALL - II